

of application based on the use of magnetron sputtering system. The advantages of magnetron sputtering systems are even processing of flat surfaces with large area; the available gases used by the system; simplicity of design.

MAGNETRON SPUTTERING SYSTEM OPERATION

Coating formation is done with sputtering of the target by ions of the working gas in the abnormal glow discharge. The principle of operation of magnetron sputtering system is shown in figure 1. The main elements of MSS are cathode target, anode, magnetic system. The lines of force are closed between poles of magnetic system. The surface of target is placed between the points of entry and exit of the force lines of the magnetic system. The surface is sprayed actively and takes the form of closed track 6. The geometry of track is determined by the form of poles of the magnetic system. The water is supplied in the body of magnetron sputtering system to cool the target [2].

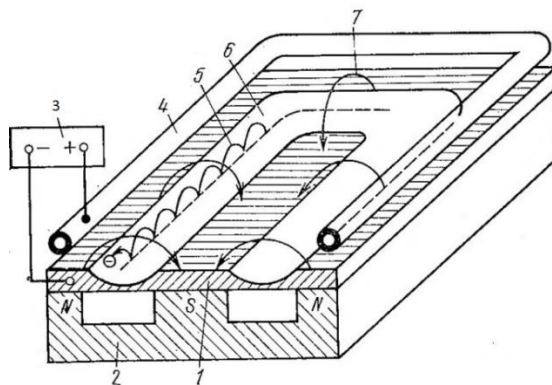

1 – cathode target; 2 – magnetic system; 3 – power supply unit; 4 – anode; 5 – trajectory of the electrons; 6 – area of erosion of the cathode surface; 7 – force lines of magnetic system.

Figure 1. Magnetron sputtering system

The magnetron sputtering system is placed in a vacuum chamber. The system is electrically isolated from the chamber and the equipment. Working gas is supplied in the chamber after pumping out the air volume. Magnetic trap facilitates the ignition of the discharge, providing electron density greater than in the remaining volume.

REFERENCES

1. Krivobokov V. P., Sochugov N. S., Solovyov A.A. Plasma coverings (methods and equipment): The manual - Tomsk: Publishing house of TPU, 2008. – 104 p.
2. Danilin B. S., Syrchin V. K. Magnetron sputtering system – M.: "Radio and communication", 1982 – 72 p.

COMPUTER MODEL OF THE «ASTRA» PULSED ELECTRON ACCELERATOR

M. A. Serebrennikov, I. S. Egorov

National Research Tomsk Polytechnic University,

Russia, Tomsk, Lenina ave., 30, 634050

E-mail: smakk_22@mail.ru

Paper shows the process of creating of computational model for a pulsed electron accelerator "ASTRA" [1] (accelerating voltage up to 460 kV, beam current pulse duration of 75 ns (FWHM), pulse energy of up to 10 J for pulse repetition rate of up to 50 pps). Multisim software was used for electrical processes simulation.

The computational model is based on a schematic diagram of the accelerator, complemented with equivalent constructive elements of the accelerator - the parasitic inductance and capacitance. When the amplitude of the voltage pulse is 400-460 kV, the energy up to 20% of total can be accumulated by parasitics. The values of the parasitic

capacities of the high-voltage insulator structure were evaluated by Elcut simulation environment with the using of the finite element method for electric field computation. The computational model of the vacuum electron diode was created. Model is based on the analysis of the experimental curves of the diode impedance for the previously constructed model of the generator [2]. Matching of both models of the generator and the diode allowed simulating of the whole «ASTRA» accelerator. Verification of the accelerator model was carried out by comparing the simulation results and the results obtained experimentally (Fig. 1).

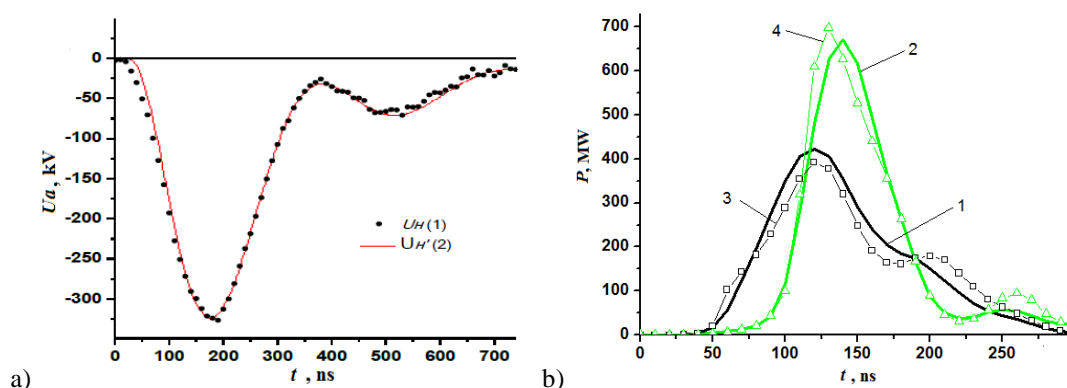

Figure 1 a). Comparison of real (1) and simulated (2) voltage pulses. b). Real (1,2) and simulated (3,4) power pulses in the diode of the accelerator.

The amplitude and the shape of the voltage pulses obtained experimentally and by modelling agree satisfactorily (Fig. 1a). It is found that in determining the power (Fig. 2b) and the value of the energy released in the diode, the error introduced by the model does not exceed 7%.

REFERENCES

1. Egorov I., Esipov V., Remnev G., et. al., A high-repetition rate pulsed electron accelerator // Proceedings of the 2012 IEEE International Power Modulator and High Voltage Conference. – San Diego, 2012, – pp. 716-719.
2. Egorov I. S. Note: Numerical simulation and experimental validation of accelerating voltage formation for a pulsed electron accelerator // Review of Scientific Instruments. – 2014. – Vol. 85. – Iss. 6. – P 066112.

THE RESERCH OF INFLUENCE OF PLASMA IMMERSION ION IMPLANTATION OF TITANIUM ON HYDROGEN SORPTION OF Zr-2,5% Nb

A.N. Sutygina, E.B. Kashkarov, N.N. Nikitenkov

National Research Tomsk Polytechnic University,

Russia, Tomsk, Lenina ave., 30, 634050

E-mail: sutygina2013@mail.ru

Zirconium and its alloys are important constructional materials of light-water nuclear reactors. Under the influence of radiation, radiolysis of water occurs and hydrogen is released, which leads to hydrogen embrittlement. One of the ways of the zirconium alloys protection from hydrogen embrittlement is an ion surface modification. The influence of the plasma immersion ion implantation (PIII) of titanium into Zr-2,5% Nb alloy on its hydrogen sorption is studied in this report.

The samples size: diameter – 30 mm, thick – 1 mm. The surfaces of the samples were polished. The roughness of the samples is 0,567 μm . The titanium implantation into Zr-2,5% Nb was carried out at the installation «Raduga-Spectrum» [1]. The implantation time was 15 min. Samples were pre-cleared in argon plasma at 0,06 Pa pressure during