

**SYNCHRONOUS MOTOR FOR DRIVING MECHANISMS
IN CHEMICALLY AGGRESSIVE ENVIRONMENT**

Fedorov D.F., Leonov S.V., Melnichuk O.V.

Scientific supervisor: Professor Garganeev A.G.

Tomsk Polytechnic University, Russia, Tomsk, Lenin str., 30, 634050

E-mail: Danil-ihp@yandex.ru

**СИНХРОННЫЙ ЭЛЕКТРОДВИГАТЕЛЬ ДЛЯ ПРИВОДА МЕХАНИЗМОВ
В ХИМИЧЕСКИ АГРЕССИВНОЙ СРЕДЕ**

Федоров Д.Ф., Леонов С.В., Мельничук О.В.

Научный руководитель: Гарганеев А.Г., профессор, д.т.н.

Национальный исследовательский Томский политехнический университет,

Россия, г.Томск, пр. Ленина, 30, 634050

E-mail: Danil-ihp@yandex.ru

***Аннотация.** В данной статье рассматриваются вопросы исследования синхронных машин дискового типа герметичного исполнения для использования в составе оборудования химической отрасли. Приведены результаты моделирования машины дискового типа с магнитосвязанными дисками и данные, полученные при экспериментальном исследовании электромагнитных потерь в герметизирующей перегородке макетного образца.*

Researched design is a sealed electric machine is designed to work on the nuclear and chemical industries to ensure the personnel and the environment protection from the process equipment harmful effects. Sealed machines operation has shown that they have a short life due to the unfavorable operational environment properties[1]. One of the weak points in the sealing machine is a joint shaft to the actuator node. The most common sealing engines method are thermowells which are installed between the electrical machine stator and it's rotor . However, this method, due to energy reduction raises the developing a new type of sealed electrical machines question. The scientific and technical literature analysis in the designing sealed electrical machinery showed that this type of drive development requires solving a number of problems. Solving this problem is possible due to advances in the rare earth permanent magnets development and electric machines study.

Nowadays, the industry produces sealed asynchronous motors with nominal speed 1500 and 3000 rpm. The thermowells thick walls increase the air gap reluctance and reduce the electromechanical energy conversion. Hermetic motor construction in such a way has the disadvantage of increasing the machine air gap, because of the magnetomotive force (MMF) drop and significantly reduced primary magnetic flux and, as a consequence, the efficiency and electromagnetic torque.

The industry needs require substantially sealed drives operating in low rpm. A common solution in such cases is a high engine works in conjunction with gear. Analysis positions efficiency leads to the conclusion that the total mass, dimensions, cost and efficiency in this approach are not very good. Therefore, a sealed gearless low-speed electric motor has a great practical interest.

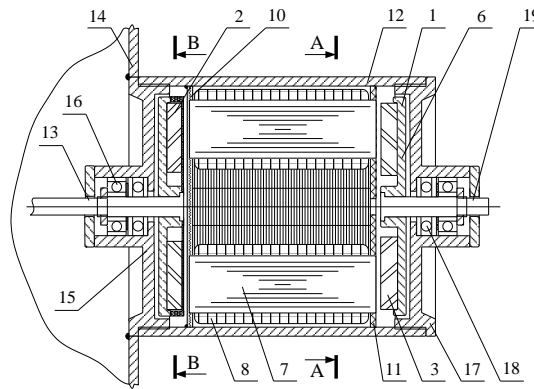

Figure 1. The design of a sealed synchronous motor with a magnetically coupled disk type rotors

On the figure 1 following parts are shown: 1, 2 – a rotors; 3 – a magnets; 6 – a yoke; 7 – a stator; 8 – rods; 10 – a sealed bulkhead; 11 – a frame; 12 – a case; 13 – a shaft; 14 – a process vessel part; 15,17 – a shields; 16,18 – a bearings.

The obvious advantages of the disk structure of the HEV are:

- Absolute tightness due to lack of mechanical connection between the rotors. In this case, the formation of the electromagnetic torque involves both of the rotors with the poles, made of rare earth permanent magnets are installed;
- Increasing reliability of the equipment and increasing the life of the drive, due to the fact the main part of the machine is away from the area of the process;
- Increasing efficiency without compromising the number of poles and the resultant velocities in the range of from about 30-1000 rpm without using additional reduction steps [1,2];
- A higher moment per unit volume of the rotor.

These factors cannot be ignored, due to the increasing of the air gap (due to the partition of the stator), while the same value of the magnetomotive force(MMF), magnetic field decreases in the gap and decreases consequently the electromagnetic torque. However, it should be noted that the generated magnetic field of the modern permanent magnets based on rare-earth elements, though depends on the size of the air gap, but is almost a linear function, and even in the open magnetic system it does not decrease less than 0.25 Tesla. The absence of the stator yoke in this design reduces the influence of the leakage flux and allows the development of a machine with a relatively low inductance coils [2].

This electrical machine design lacks obvious disadvantage of having salient magnetic system performance of small diameter. Improving the machine performance was achieved by selecting the launch mode and a rigid connection between the disc rotor absence, which gives the shifting MDS effect to obtain a sinusoidal magnetic field. Thus, starting the engine can be realized by the rotor disks rotation on a certain angle. The displacement provides not only the distribution of MDS advantage, but also gives smooth rotor movement.

In this regard, it was necessary to perform some theoretical studies in electro-magnetic processes in this machine with its magnetic coupling rotors to reduce tooth effect. Also the machine dynamic characteristics analysis and the air gap impact on the external characteristics form were made.

To build the calculation program a mathematical model based on the field sources integration method has been used [4]. The calculation field model obtained the magnetic field and the magnetization in the magnetic

material vectors distribution (Figure 2).

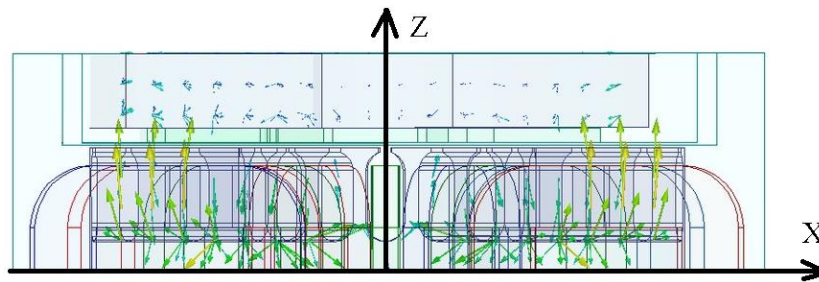

Figure 2. The disk-type machine magnetic field

Fig. 3 shows the mechanical engine power characteristics (in arbitrary units) as an angle shear rotors function. The shift angle rotor maximum value corresponds to the machine pole pitch. The studies found that if the rotor poles displacement angle is between the $6 \dots 8^\circ$ the machine power is reduced slightly.

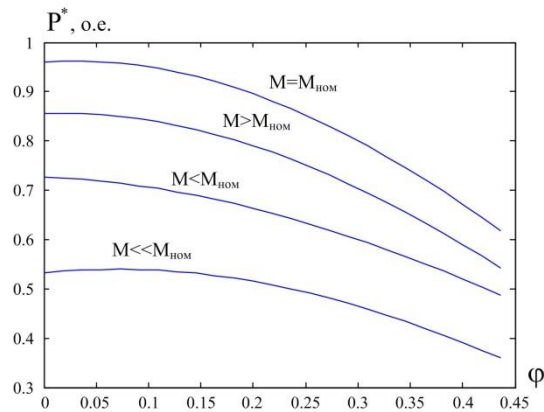

Figure 3. Influence the displacement on power poles machines

Next, to confirm the results and determine a conductive sealing disk partitions influence degree on the engine, laboratory stand was manufactured. It includes the frequency converter and the engine model sample. According to studies, the electromagnetic losses caused by the conductive sealing screen installation, can almost be ignored, if the synchronous disc type motor rotation speed does not exceed 600 rpm and a six-pole magnetic system design is used. The theoretical results have been confirmed by experiment, with the following characteristics: a machine stator outer diameter is 105 mm; torque is about 4 N·m; a speed range is 30 - 1000 rpm.

In conclusion, it should be noted that a new type engine introduction increases economic efficiency by reducing the costs of repair and increase the reserve maintenance periods.

References

- [1] Z.B. Kantorovich Bases for chemical machines and apparatus design, Moscow, 1961.
- [2] N.P.Kostenko, L.M. Piotrovskiy, Electrical machines, 1973.
- [3] T.Kenio, Stepping motors and their microprocess controls, Clarendon press, Oxford, 1984.
- [4] S.V.Leonov, O.P.Muravlev, V.E.Kalaev. Questions of studying the three-dimensional magnetic field electrical machine with axial magnetic flux // Izvestia Vuzov, electromechanika (2004) p8.