

2.Соколов В.Я. «Повышение эффективности размагничивания деталей после магнитопорошковой дефектоскопии»

3.Размагничивание труб перед сваркой при ремонтных работах на ЛЧМГ – газовая промышленность[2] №10, 2012, автор Е.А.Дасис, В.А. Сетефанский (ООО “Газпром трансгаз Ухта”)

4.Устройства размагничивания 2.980 (EMAG M / EMAG F)
http://www.foerster.ru/f_prod/ts_dept/comp_ts/2980.pdf

RADIOGRAPHY INSPECTIONS ON DUPLEX STAINLESS STEEL ON CHOCK BODY AS PER ASTM A995 –4A &E747, API6

Shah R.

Tomsk Polytechnic University, Tomsk

Scientific adviser: M.V. Burkov, the Department of Material science in Engineering

Introduction

The present invention relates to a stainless steel alloy, closer determined a Duplex stainless steel alloy (LDX 2101, 23041, LDX 2404 and others) with ferritic-austenitic matrix and with high-resistance to corrosion in combination with good structural stability and great mechanical properties which make it suitable for use in applications where a high corrosion resistance is required as in chloride-containing environment, such as oil refining and hydro metallurgical processes. Duplex stainless steel present high level of alloying elements contains such as chromium, nickel, molybdenum and nitrogen which should be properly balanced in order to achieve volumetric fabrication of ferrite and austenitic as to given, this mixture also lead to marked refinement in the grain size of both phase.

This type of steel has the following properties:

- High chloride pitting and crevice corrosion resistance due to the chromium, molybdenum, tungsten and nitrogen (Pitting Resistance Equivalent Number – PREN – exceeds 45).

- Chloride stress corrosion cracking (SCC) resistance significantly greater then austenite stainless steel series of 300.

- The good quality of fabrication.

- The max 0.5 weight-% of silicon to increase the flowability during production and welding.

- High strength – the range of 0.2% proof strength from is from 400 – 550 MPa that can lead to reduced section thickness and therefore to reduced weight.

- Good welding ability in thick sections – much better than Ferritic.
- Good toughness – much better than Ferritic particularly at low temperature, typically down to minus 50 deg C, stretching to minus 80 deg C.

Classifications of DDS

Steel name	International steel No			Chemical composition, % by wt.					
	EN	UNS	ISO	Typical values					
				C	N	Cr	Ni	Mo	Others
LDX 2101 [®]	1.4162	S32101	4162-321-01-E	0.03	0.22	21.5	1.5	0.3	5Mn Cu
23041	1.4362	S32304	4362-323-04-I	0.02	0.1	23	4.8	0.3	Cu

**Type of DSS can be changed according to the production companies and customers' requirements

Mechanical properties of DSS

Steel name	Mechanical properties	Sym	Unit	Minimum values, according to EN 10088			Typical values		
				P	H	C	P (15 mm)	H (4 mm)	C (1 mm)
LDX 2101[®]	Proof strength	R _{p0.2}	MPa	450	480	530	500	560	610
	Tensile strength	R _m	MPa	650	680	700	700	755	810
	Elongation	A5	%	30	30	30/20 ¹	38	35	293
	Hardness	HB					225	235	992
2304	Proof strength	R _{p0.2}	MPa	400	400	450	450	600	620
	Tensile strength	R _m	MPa	630	650	650	670	765	790
	Elongation	A5	%	25	20	20/20 ¹	40	30	263
	Hardness	HB					210	235	992

**Properties can also utilize by alloying as per the requirement and application.

There is great perspective for this steel to be used in wide range of applications where the high corrosion and strength is required, for example in pressure vessels, heat exchangers, tanks, piping systems and tankers. One of the main production methods of complex-shape parts like pipeline choke body that is used in pipeline construction is traditional green sand casting process. There are a lot of defects like inclusions, pores that may emerge during the casting process and the non-destructive testing evaluation is required.

Radiography today is one of the most important, versatile of all the nondestructive test methods used by modern industry. Employing highly penetrating x-rays, gamma rays, and other forms of radiation that do not damage the part itself, radiography provides a permanent visible film record of internal conditions, containing the basic information by which soundness can be determined.

The present research deals with the radiography examination of duplex stainless steel choke body.

Purpose of Inspections

The international standard and specifications requirements and give recommendations for the performance, dimensions and function interchangeability, Design, materials, tastings & inspections to the remanufactures of wall head and Christmas trees equipment for use of petroleum and gas industries for bright future API – 6. It's a set of specifications for wall head & Christmas tree equipment as stipulated by American Petroleum Institutions.

It is applicable to all petroleum and natural gas industries of drilling & production equipment – well head and Christmas tree equipment made from duplex stainless steel.

Choke: equipment used to restrict and control the flow of fluids chokes are classified according to the mechanisms used to operate them. This is not of importance to us as we are only dealing with the choke body.

As seen in Fig. 1, the fluid flows through the valve when the valve mechanism unblocks the valve body.

Principal of Testing

Radiographic testing (RT) is based on using short wavelength electromagnetic radiation passing through the material. Materials with areas of reduced thickness or lower material density allow more, and therefore

absorb less, radiation. The radiation, which reaches the film after passing through the material, forms a shadow image on a photographic film (radiograph). Areas of low absorption (slag, porosity) appear as dark areas on the developed film (radiograph). Areas of high absorption (dense inclusions) appear as light areas on the developed film.

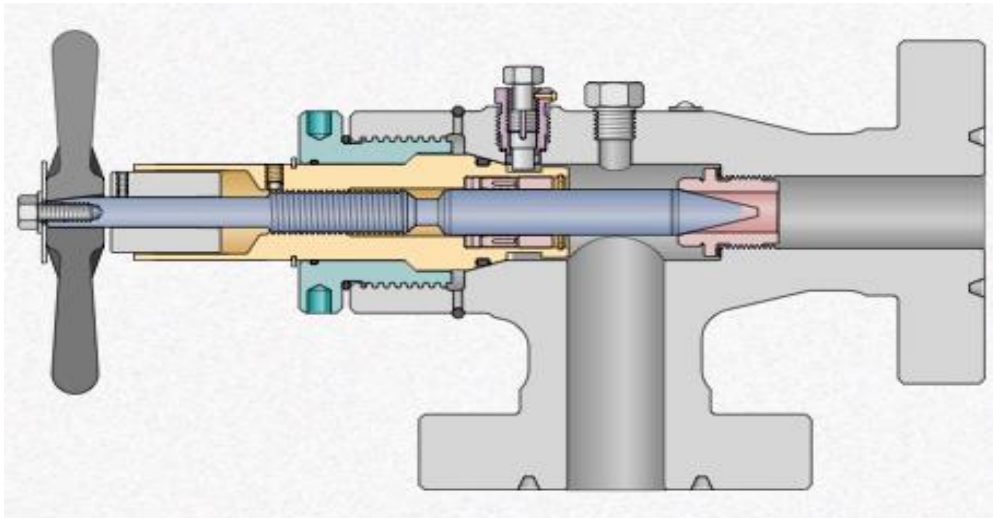

Fig. 1. Choke assembly.

Types of testing methods

Single wall, single image (SWSI) is a technique whereby the radiographic source is placed inside the pipe by some suitable method, the film wrapped around the outside of the pipe and the exposure made as shown in Fig. 2. This may also be known as a panoramic exposure. The IQI is placed on the outside of the pipe immediately beneath the film. Both X- and gamma-radiography can be used, the source being placed in position by the use of a pre-placed spider or by means of a crawler unit. This method is most commonly used for the inspection of pipelines where the weld can be radiographed in one exposure, making the technique rapid and cost effective.

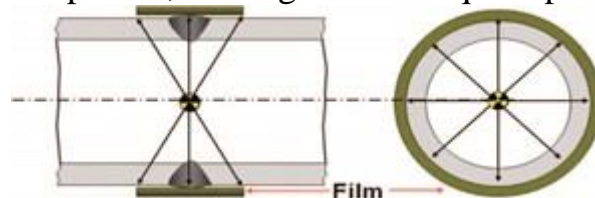

Fig. 2. Single wall, single image (SWSI)

Where access to the bore is not possible or the pipe diameter is too small to permit the use of an internal source then the double wall, single image (DWSI) technique is used. Here the film is placed on the outside of the

pipe on the farthest side from the radiographic source, as shown in Fig. 3. The source may be offset slightly to avoid an image of the upper part of the weld to be projected onto the film or directly in line. The source may be close to or a substantial distance from the pipe, the location being a compromise between a less sharp image but short exposure time for a small stand-off and sharper image but longer exposure time for a large stand-off. The need to penetrate two wall thicknesses means that the sensitivity will be poorer than with the single wall single image technique. The technique also requires multiple exposures to enable the complete circumference of the pipe to be examined – specification or contract requirements frequently specify the minimum numbers of exposures to ensure complete coverage and images of an acceptable quality. The technique is generally used on pipes over 80mm in diameter.

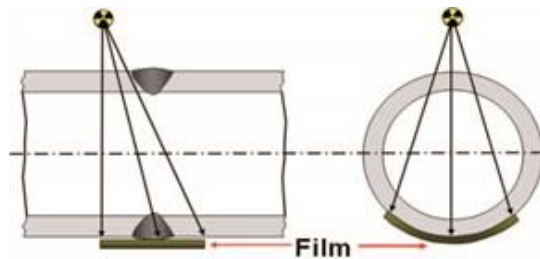

Fig. 3 Double wall, single image

The last technique is double wall, double image (DWDI), generally used only on pipes less than 75-80mm in diameter.

Experimental results

We performed the radiography inspection were carried out by SWSI/DWSI techniques as per the locations throughout the casting body, we used under the AGFAD7 film, the inspection was performed by the ASTM E747/E186 standards and reference procedure for testing as per Cameron X008063 REV06 article of radiography examinations.

The front screen level of the film was 0.15/0.25 and back screen level was 0.15, the radiation source for the experiment was cobalt & iridium & source film distance as per the location points to coverage the 100% area of the chock body to detect the micro defects like gas porosity inclusion and micro crack throughout the casting body.

Sr. No	Locations	Source	Film Size (in.)	Thick-ness (mm)	Source Film Distance (mm)	Experiment Time (min)	Result
1	S1/A-B	CO	15 x 21	160	60	2Hrs	NSD

2	S1/B-C	CO	15 x 21	160	60	2Hrs	INCL
3	S1/C-D	CO	15 x 21	160	60	2Hrs	NSD
4	S1/D-E	CO	15 x 21	160	60	2Hrs	INCL
5	S1/E-F	CO	15 x 21	160	60	2Hrs	NSD
6	S1/F-A	CO	15 x 21	160	60	2Hrs	INCL
7	S2/A-B	CO	15 x 21	160	60	2Hrs	NSD
8	S2/B-C	CO	15 x 21	160	60	2Hrs	NSD
9	S2/C-D	CO	15 x 21	160	60	2Hrs	NSD
10	S2/D-E	CO	15 x 21	160	60	2Hrs	NSD
11	S2/E-F	CO	15 x 21	160	60	2Hrs	NSD
12	S2/F-A	CO	15 x 21	160	60	2Hrs	NSD
13	S3/A	CO	12 x 9	51+51	70	1 Hrs	INCL
14	S3/B	CO	12 x 9	51+51	70	1 Hrs	NSD
15	S3/C	CO	12 x 9	51+51	70	1 Hrs	NSD
16	S4/A	CO	12 x 9	65+65	70	1 Hrs	NSD
17	S4/B	CO	12 x 9	65+65	70	1 Hrs	NSD
18	S4/C	CO	12 x 9	65+65	70	1 Hrs	NSD
19	S5/A –B	CO	12 x 5	75	20	50 Sec	NSD
20	S5/B-C	CO	12 x 5	75	20	50 Sec	NSD
21	S5/C-D	CO	12 x 5	75	20	50 Sec	NSD
21	S5/E-F	CO	8 x 4	75	20	50 Sec	NSD
23	S6/A –B	IR	12 x 6	40	22	3 Min	NSD
24	S6/B-C	IR	12 x 6	40	22	3 Min	NSD
25	S6/C-D	IR	12 x 6	40	22	3 Min	NSD
26	S7/A –B	CO	12 x 5	110	17	2 Min	NSD
27	S7/B-C	CO	12 x 5	110	17	2 Min	NSD
28	S7/C-D	CO	12 x 5	110	17	2 Min	INCL
29	S7/E-F	CO	12 x 5	110	17	2 Min	NSD

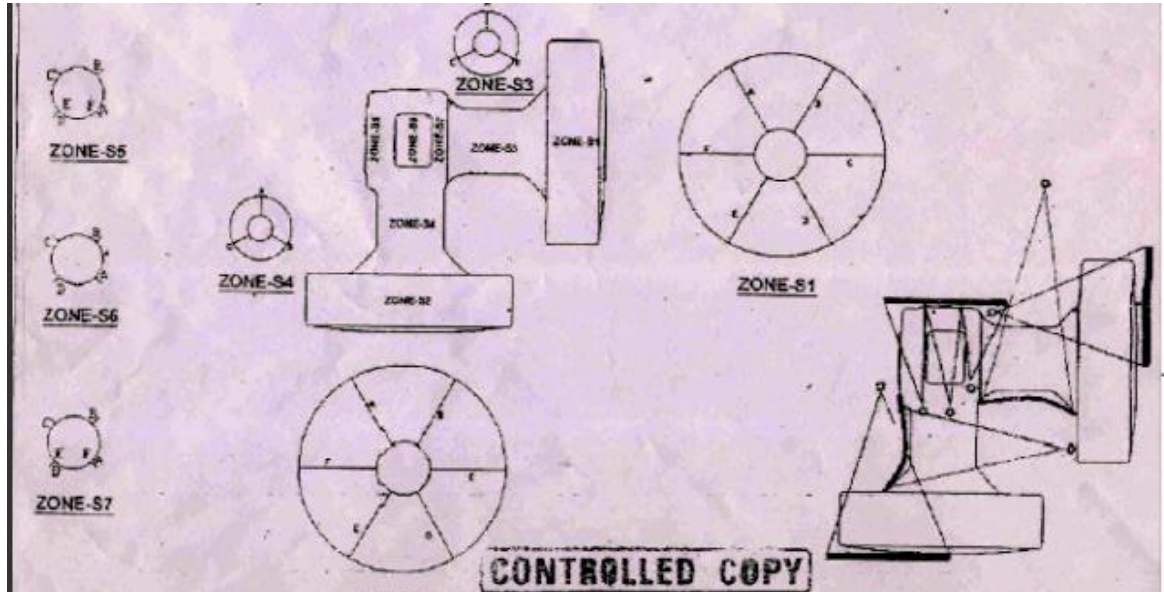

Fig. 4. Radiography shooting sketch (drawing is affiliated to the manufacture controlled copy).

Analysis and Conclusions

The research of Radiography inspections on chock body made by duplex stainless steel carried out then inclusion through the whole casting body. No significant defect or discontinuity was observed under radiography test, Result which is acceptable. As per the qualification of Cameron procedure reference – X008063 REV – 06.

Reference

1. CamronX-303610-01 FAQ procedure for Cast Duplex & Super Duplex SS parts
- 2.X – 8063 Cameron Procedure for Radiographic inspections & Examination
- 3.International atomic energy agency, Vienna International Centre, Vienna, Austria
- 4.ASTM- A9955-4A &E757, Standard Specification for Castings, Austenitic-Ferritic (Duplex) Stainless Steel, for Pressure-Containing Parts,
- 5.ASTM E994- Standard Guide for Editorial Procedures and Form of Product Specifications for Steel, Stainless Steel, and Related Alloys
- 6.TWI welding and Inspection institutions -Granta Park, Great Abington, Cambridge,CB21 6AL,United Kingdom
- 7.Kodak radiography- Eastman Kodak company, Rochester, New York 14650

8. British steel associations article Duplex Stainless Steels - A Simplified Guide, Park Suite, Forsyth Enterprise Centre, Bramall Lane, Sheffield

АНАЛИЗ МЕХАНИЗМОВ УПРАВЛЕНИЯ ПРОЦЕССАМИ УТИЛИЗАЦИИ И ИСПОЛЬЗОВАНИЯ ОТХОДОВ ДЛЯ СОЗДАНИЯ РЕКРЕАЦИОННЫХ ЗОН В УГОЛЬНОЙ ПРОМЫШЛЕННОСТИ

Шорохова А.В.

*Сибирский государственный индустриальный университет,
г. Новокузнецк*

Практически на всех урбанизированных территориях существуют экологические проблемы. Более 80% промышленных отходов возникает в процессе добычи и обогащения полезных ископаемых [1]. Более 40 тыс. га земли занято под складирование отходов [2].

В связи с ухудшением экологической обстановки продолжительность жизни населения в Кузбассе сокращается [3]. В результате происходит ассимиляция. На место коренного населения приходят лица с более низким образованием.

Исходя из этого накопленные отходы стали главной причиной экологического загрязнения, ухудшения социально-экономического положения населения. В этой связи являются актуальными исследования по разработке механизма управления системой утилизации и использования отходов для создания рекреационных зон в угледобывающих регионах.

Зачастую большинство механизмов природоохранной деятельности направлены лишь на снижение и ограничение негативного воздействия предприятия на окружающую среду.

В законодательстве России существуют различные методы экономического регулирования (рисунок 1), стимулирования, льготы и штрафы в области рационального природопользования (закон «О недрах», «Об охране окружающей среды», Распоряжение Правительства РФ «Об Экологической доктрине Российской Федерации» и т.д.).

Существующие механизмы управления эколого-экономическими системами включает в себя следующие методы экономического регулирования охраны окружающей среды [4, ст. 14]:

– разработка государственных прогнозов социально-экономического развития на основе экологических прогнозов;