

# HUMAN LOCATION CONTROL SYSTEM IN THE ILLUMINATED AREA

*Berdybekov S.B.*

*Tomsk Polytechnic University, Tomsk*

*Scientific supervisor: Yurchenko A.V., PhD, professor of PMNDT department*

Modern city lighting systems have higher requirements for energy conservation and resource efficiency because of rising energy costs. Smart lighting systems conform to these requirements. Listed below are the advantages of smart lighting system over a conventional one:

1) Standard lighting systems have set lighting time, which does not depend on the actual daylight time and weather conditions; this issue is solved in smart lighting systems by taking this dependence into account and making appropriate adjustments;

2) Switching on and off in commonly used lighting systems does not depend on the presence of pedestrians and moving cars; because of this, energy can be wasted for a long time [1].

The main goal of this project is to develop a smart street lighting system based on the Beaglebone microcomputer. The embedded systems that are used to control smart lighting systems monitor the level of lighting, process information signals from sensors, and maintain connection with each other. An information signal from the sensor indicates the need for correction of lighting, and adjustment is carried out in several stages. This year, our team has developed the following structure of the lighting system based on Beaglebone microcomputer [6]. The lighting system is a combination of the central device and the street lamps connected to it (Figure 1).

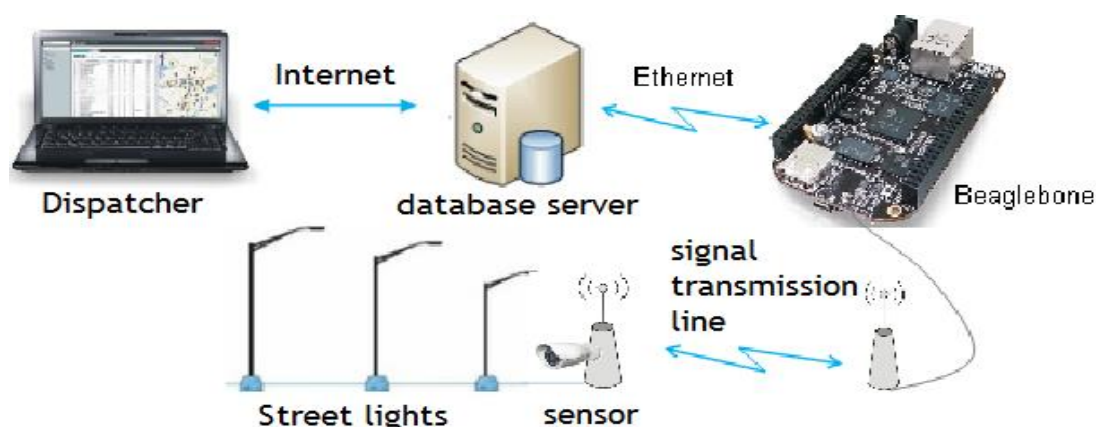

*Figure 1. Structure of a smart lighting system*

Beaglebone microcomputer is the central control unit. Each lamp has a system of communication and detection. The first system is used for connecting the lamp to the Beaglebone, the second one serves for detection of objects of control (pedestrians). When pedestrians enter the control area, a sensor is triggered, and then a signal is transmitted to the Beaglebone, which switches on nearby lights. The system consists of two parts: hardware and software. The complexity of this project is to create a reliable method of object recognition. Currently, the sensors are triggered falsely or fail to trigger, and stop working when an object stops. Integrated sensors and sophisticated data processing algorithms can provide a solution to this problem [6].

The paper deals with methods of control object detection and possible options for implementation of smart lighting sensors, which are the main part of the lighting system. Listed below are the advantages and disadvantages of various sensors, which can be used in lighting systems.

### **Methods of person detection in the control zone**

#### **Infrared sensor**

The operating principle of infrared (IR) sensors is based on registration of changes in infrared radiation. When an object moves, its IR radiation is serially focused by various lenses of the system on a sensor (the quantity of lenses usually varies from 20 to 60 pieces). According to the degree of sensitivity, infrared sensors are divided into motion sensors and presence detectors [5].

Advantages of infrared sensors:

- 1) The ability to adjust the distance and angle of detection of moving objects.
- 2) Complete safety for human and animal health during operation; these sensors only work as receivers without emitting anything.

Disadvantages of infrared sensors:

- 1) The possibility of false positives due to the source of infrared radiation, which include the warm air, cars, sunlight, rainfall.
- 2) The relatively small range of operating temperatures.
- 3) These sensors do not detect objects covered by IR-proof materials.

After analyzing the characteristics of the infrared sensors and the possibilities of implementing them for automatic control of a lighting system, we came to a conclusion that it can be problematic, but they can be used when combined with other types of sensors that compensate the deficiencies of the infrared sensors.

## **Ultrasonic sensor**

Ultrasonic sensors emit a sound pulse that reflects off objects entering the wave field. The sensor then receives the reflected sound, or “echo”. Detection of the sound generates an output signal for use by an actuator, controller, or computer. The output signal can be analog or digital. Ultrasonic sensing technology is based on the principle that sound has a relatively constant velocity. The time for an ultrasonic sensor’s beam to strike the target and return is directly proportional to the distance to the object.

Sensors of this type have the following advantages:

- 1) They are relatively inexpensive.
- 2) They are not sensitive to environmental influences.
- 3) They can detect the motion of the object, regardless of the material.

Disadvantages of ultrasonic sensors:

- 1) Ultrasonic frequencies can agitate animals.
- 2) Relatively low range of action.
- 3) These sensors only react to sharp movements, so it is possible to deceive an ultrasonic motion sensor by moving smoothly [2, 3].

## **Radio wave sensor (microwave)**

The principle of operation of these devices is based on the interference of radio waves in the centimeter range or the Doppler Effect. Radio waves emitted by the device are reflected from a moving object and change their length or frequency. The source emits high-frequency electromagnetic waves (usually 5–8 GHz), which are reflected from the surrounding objects and registered by the sensor. The resulting signal is amplified and filtered to avoid registration of objects that move either too slow or too quick. Only those speeds are selected (1 to 5 km/h) that are inherent to human movement.

Sensors of this type have the following advantages:

- 1) They can detect objects that are concealed by insulated or weakly conductive obstacles: thin walls, doors, windows, etc.
- 2) The efficiency of these sensors is independent of the ambient temperature and the objects’ temperature.
- 3) They are able to respond to slightest movements.

Disadvantages of radio wave sensors:

- 1) They have a higher cost compared to other types of sensors.
- 2) The possibility of false positives due to movements in the surveillance zone; such sources of false positives may be, for example:
  - a) Vibration from operating electrical equipment.
  - b) Small animals and birds.

Microwave radiation is unsafe for human health, so it is necessary to choose microwave motion sensors with low radiation power: continuous radiation with power density up to 1 MW/cm<sup>2</sup> is safe [4].

### **Visual inspection method**

Developments in video recording and processing technology allow using them not only in traditional cases such as recording and playback of video, but also in non-obvious cases, for example, using video cameras as smart sensors. However, camera sensors are hardly ever used in smart lighting systems. Development of advanced data processing algorithms allows designing such systems.

Advantages of the visual inspection method:

- 1) Larger area of coverage in contrast to other methods.
- 2) Identification of not only the motion, but the presence of the object.
- 3) Low probability of false positives.

At the same, disadvantages of this method are:

- 1) The difficulty of creating the data processing algorithms.
- 2) Reliance on the lighting level [6, 8].

After analyzing all of these sensors, their advantages and disadvantages, we selected the combination "infrared sensor – ultrasonic sensor" as one of the most optimal. High dependence of infrared sensors on the environment is overcome by using an ultrasonic sensor; low sensitivity of the ultrasonic sensor can be improved by the infrared sensor. At the moment, the integration of the two sensors was implemented in an experimental model of smart lighting system with LED as a light source. To increase the efficiency of human detection in the control zone, ultrasonic and infrared sensors were integrated into the system controlled by BeagleBone Black microcomputer. The C++ programming language was used to write the LED management program, which processes signals from the sensors and switches on the LED (Figure 2) [6].

In the course of the study we analyzed the main methods of detection of movement and human presence and determined the best pair of sensors to be used in the smart lighting system. Using a combination of detection methods can increase the accuracy and sensitivity of the lighting system. We intend to use the model as a base to develop further solutions to increase the accuracy and response sensitivity of the detection system.

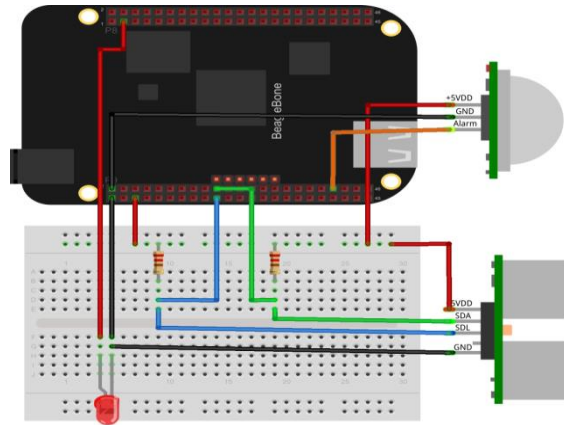

Figure 2. Experimental model of smart lighting system

## References

1. Srivatsa, D.K.; Preethi, B.; Parinitha, R.; Sumana, G.; Kumar, A. Smart street lights / Proceedings of 2013 Texas Instruments India Educators' Conference (TIIEC), 2013, p. 103-106.
2. Technical means of detection [Электронный ресурс]. – URL: <http://www.nicohrana.ru/forum/viewtopic.php?f=18&t=28> - Загл. с экрана - Дата обращения: 20.01.2015
3. Motion sensors. Main types and their characteristics. Areas of use [Электронный ресурс]. – URL: <http://rozetkaonline.ru/poleznie-stati-o-rozetkah-i-vykluchateliah/item/54-datchiki-dvizheniya-osnovnye-vidy-i-ikh-osobennosti-oblasti-primeneniya#ultra> - Загл. с экрана - Дата обращения: 23.01.2015
4. Radiowave and the combined motion detectors. [Электронный ресурс]. – URL: <http://library.espec.ws/books/guard/CHAPTER3/3-3.htm> - Загл. с экрана - Дата обращения: 29.01.2015
5. Vlasuk, N.P. Passive infrared motion detector/ Радиоаматор. - 2006. - №5. - С. 31-37.
6. Goponenko, A.S., Matveev, I.G., Yurchenko, A.V., Kovalev, M.K. Development of the detection system for intelligent lighting system based on a microcomputer Beaglebone. // Ползуновский вестник.-2015.-№3.-С.2.
7. Derek Molloy. Tools and Techniques for Building with Embedded Linux, John Wiley & Sons, Inc. 2015.
8. Zhijun Jiang; Mingfa Wang; Wei Gong. The video capture and processing research on Smart car road information based on OV7620 camera / Proceedings of 2010 2nd International Asia Conference on Informatics in Control, Automation and Robotics (CAR), Vol. 1, 2010, p. 108-111. DOI: 10.1109/CAR.2010.5456894