

A teleoperation system to control the humanoid robot using an RGB-D sensor

E E Shelomentcev and T V Aleksandrova

Tomsk Polytechnic University, 30, Lenina ave., Tomsk, 634050, Russia

E-mail: see4me@mail.ru

Abstract. This paper presents a concept design of the work algorithm for a teleoperation control system of a humanoid robot. The humanoid robot control system needs to stabilize the robot in a vertical position in order to prevent the robot from falling. The process of design of the control system includes the design of position filter to detect the unstable positions. The application of such a control system enables to control the humanoid robot using motion capture technology.

1. Introduction

Humanoid robots have been actively developed in recent years. There are many different designs of humanoid robot constructions but not all of them have the control system that realizes adequate behavior of the humanoid robot. That is why some researchers propose using teleoperation, [1-4], to control such type of the robots. In this case, the humanoid robot is an avatar controlled by a human operator. Implementation of this technique allows the human operator to manipulate with objects remotely that is helpful, for example, in hazardous environment.

Further, we will consider the algorithm of the teleoperation control system that allows controlling humanoid robots using the RGB-D sensor (Microsoft Kinect). In our research, we use the humanoid robot BIOLOID that have actuators in every joint.

2. Control algorithm

To form the control signals we need to collect the data about the human position. Let us create the operational block that processes the data received from the RGB-D sensor. The objectives of this block are the forming of the packets with the human operator data and the initial data filtering, for example, forming of the packets only with the recognized position of the operator. When the packet is filtered, the system must inform the operator about it.

To control the position of the humanoid robot we need to set the positions of the actuators that are located in the joints of the robot. The positions of the actuators can be mapped from the angles of rotations in the joint of the human operator. It means that we need to receive the control signals that contains the information about angles of rotations.

The human body differs from the robot body because the mass of their limbs is different and it can be a reason of the robot falling that is why it is necessary to ensure the stable vertical position of the robot through the control process to prevent his falling. Thus, we need to filter unstable positions of the robot [5]. Only when all of these operations are mapped and filtered, positions of actuators can be sent to the robot.



Thus, we have an algorithm that can be showed as a row of actions:collecting filtered data, synthesizing actuators positions according to the data, filtering the actuators positions that make robot unstable and sending the actuators positions to the robot (Figure 1).

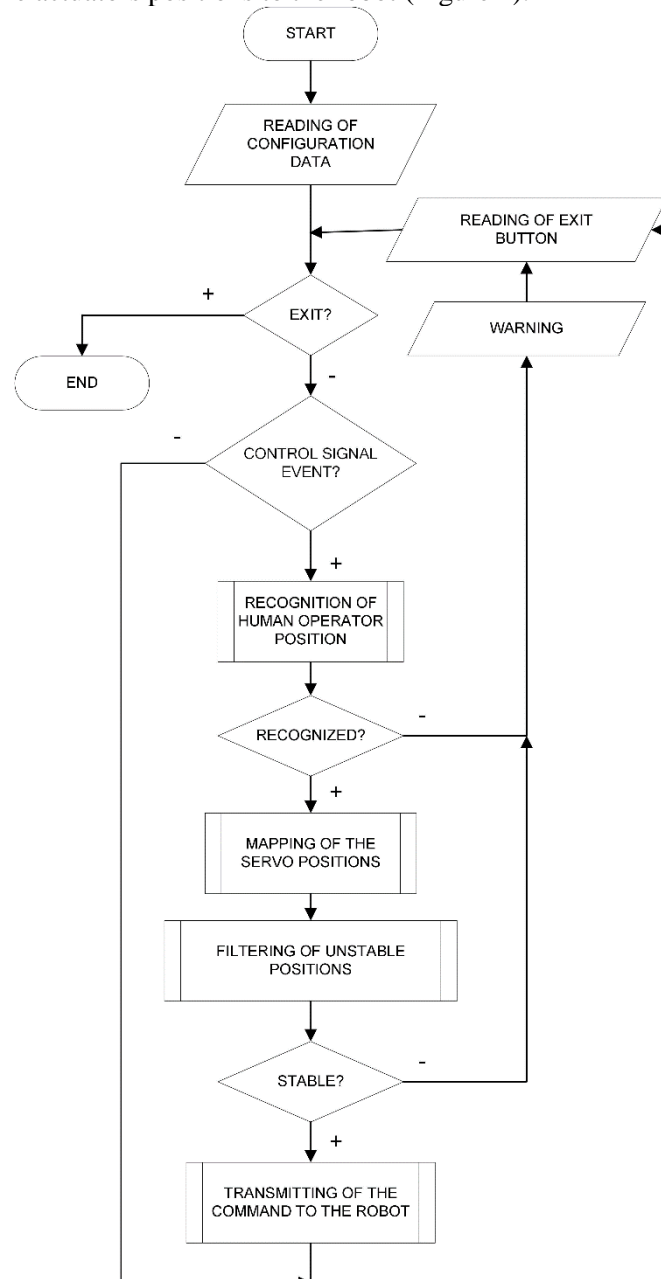

Figure 1. An algorithm of the control system work.

2.1. Collecting data using a RGB-D sensor

To control the position of the humanoid robot we need to set the positions of the actuators that are located in the joints of the robot. The positions of the actuators can be mapped from the angles of rotations in the joint of the robot. It means that we need to receive the control signals that contain the information about angles of rotations. These angles of rotations can be found as angles between the vectors formed by the control points of human operator joints (Figure 2). For example, the angle in the right elbow joint of the robot is an angle between vectors \vec{a} and \vec{b} , where \vec{a} is a vector with initial

point ELBOW_RIGHT and terminal point WRIST_RIGHT; \vec{b} is a vector with initial point ELBOW_RIGHT and terminal point SHOULDER_RIGHT. Control points of the human operator are received from the RGB-D sensor. The use of special software kits (Kinect SDK, OpenNI) allows one to recognize these control points on human body and to filter unrecognized human positions.

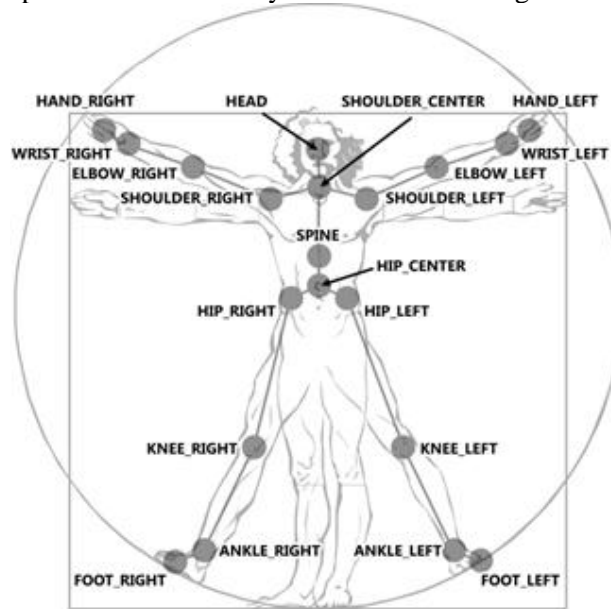

Figure 2. Control points of the human operator

2.2. Actuators control

Now we have the humanoid robot BIOLOID and we have the angles of rotation in every joint. BIOLOID has 18 controllable degrees of freedom that provided by 18 servos. Each servo has an angle constraint (Figure 3) that is it can rotate from 0 to 300 degrees. That is why we need to map our angles of rotations to positions of servos in view of the constraint. After this, we need to input servo positions to model the robot to check the stability of the robot position using position filter [5]. If the position of the robot is unstable then the control system warns the human operator about instability, moreover the control system sends the control signals to robot actuators. Implementation of the filter allows robot to move only from one stable position to another. Thus, the humanoid robot can stay stable even if the control system has time-delay in communication interface.

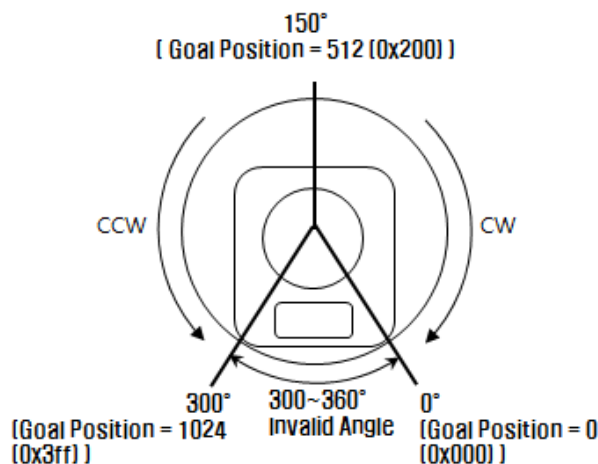

Figure 3. A robot actuator constraint.

2.3. A stability filter

The main idea of the stability filter is the check of a static stability condition [5]. We use the Denavit-Hartenberg convention to model the robot. It allows one to calculate the position of robot CoM (Center of Mass) using the positions of actuators. The CoM position is needed to check the static stability condition.

To check the static stability condition, we use a ZMP (Zero Moment Point) method that allows one to determine whether the position of the robot is stable or not considering the effect of all forces [6, 7].

The method comprises calculating the ZMP position, where both inertial and gravity forces do not produce any moment in a horizontal direction. To evaluate the position stability of the robot it is necessary to determine that ZMP is located in a supporting polygon (the area of a foot in the single support phase or the area limited by two feet in the double support phase).

If the influence of the inertial forces is neglected, ZMP is a projection of CoM on a supporting plane. In this case, the vector of the gravity force crosses the axes at ZMP, which means that the moment produced by this force is zero. Thus, to assess the position stability of the robot we need to ensure that the projection of CoM is located in the supporting polygon.

2.4. Data transmitting

When we recognize the position of the human operator, generate control commands translating them to the robot model and check the robot stability, we need to send correct control commands to the robot. There are two ways of communication with BIOLOID: the use of the ZigBee connection and the use of the cable connection. Both of them apply a UART protocol to transmit the data. That is why we need to realize the UART protocol in our software. Application of the ZigBee connection can cause time-delay in the control system work but it allows one to control the robot more efficiently without movement constraints caused by the cable. Furthermore, time-delay has no critical influence on performance and the robot stability through the control process.

3. Conclusion

In this paper, we have described the concept design of the teleoperation system of the humanoid robot. The designed control system allows the operator to control the robot using the motion capture technology that is the most ergonomic way of the humanoid control [8]. The system includes the stability control that filters all unstable positions of the robot, but it does not prevent the robot falls that are caused by external forces. The whole system allows one to control the humanoid robot effectively through the process of the movement. This paper describes only the concept of the control system and further work is the implementation of this concept in a real control system of the humanoid robot. At this moment, we have realized the basics of the forming of the control signals (Figure 4) and started to realize the stability filter in the control system of the robot BIOLOID.

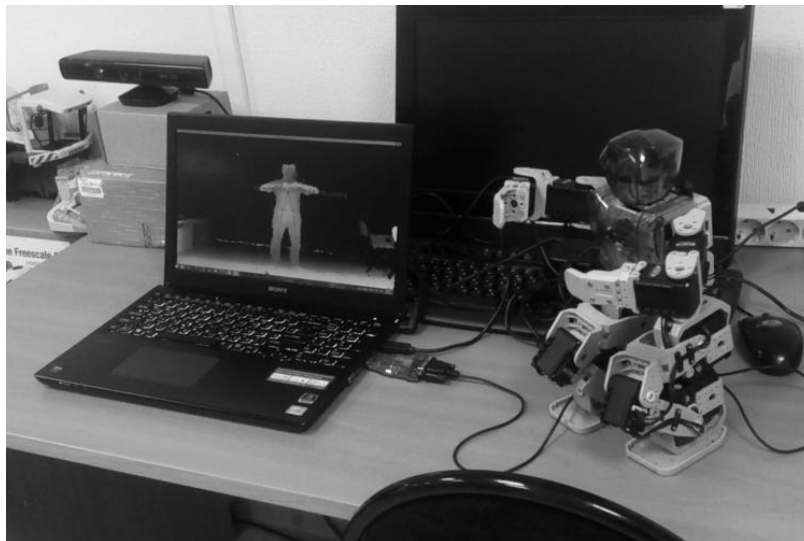

Figure 4. An experiment.

References

- [1] Sian N E, Yokoi K, Kajita S, Kanehiro F and Tanie K 2002 *IEEE/RSJ Int. Conf. on Intelligent Robots and Systems* 3
- [2] Takubo T, Inoue K, Arai T and Nishii K 2006 *IEEE Int. Conf. on Intelligent Robots and Systems* 4459–4465
- [3] Du G, Zhang P, Mai J and Li Z 2012 *International Journal of Advanced Robotic Systems* 1
- [4] Du G and Zhang P 2014 *Robot. Comput. Integr. Manuf.* **30(2)** 150–159
- [5] Shelomentcev E and Alexandrova T 2014 *IOP Conf. Ser.: Mater. Sci. Eng.* **66** 012027
- [6] Vukobratovic M and Stepanenko J 1973 *On the Stability of Anthropomorphic Systems* **15(1–2)** 1–37
- [7] Dekker M 2009 *Zero-moment point method for stable biped walking (Internsh. report, Eindhoven)*
- [8] Goodrich M A, Crandall J W and Barakova E 2013 *Reviews of Human Factors and Ergonomics* pp 175-226