

Developing the drilling tool for trenchless pipeline construction

S Povarnitsyn¹, A Martynuk², O Brusnik³

¹OOO RN-KrasnojarskNIPIneft

^{2,3} National Research Tomsk Polytechnic University, Tomsk, Russia

E-mail: ¹povarnitsynsergey@gmail.com, ²kr_nas_sh@tpu.ru, ³brusnikov@tpu.ru

Abstract. The most promising methods of underground pipeline construction are discussed. To increase the efficiency of the drilling tool for underground pipeline construction the following research methods have been used in the article: optimization method of Evolutionary strategy, finite element modeling. The influence of geometric parameters of the drilling tool on force characteristics of enlarging the drill hole has been investigated.

1. Introduction

The trenchless methods of installing an underground pipeline, for example, horizontal directional drilling (HDD), microtunneling, pipe jacking and pipe ramming are currently widespread in many fields of construction.

The most promising method of underground pipeline construction is horizontal directional drilling, but this method has a number of limitations, the main of which is the high cost due to the use of drilling fluid. The increase in this method efficiency can be achieved by several ways: using a multistage enlarging method to enlarge a hole; using drilling tools for drilling a pilot hole and enlarging a hole without using drilling fluid.

The objective of the article is to increase the efficiency of trenchless pipeline construction based on improving the drilling methods and the drilling tool.

2. Research methods

A characteristic feature of the drilling tool and its analogues is that in the course of drilling the soil is not removed from the drill hole to the surface, but is pressed into the surrounding soil.

Since the drilling tool consists of a helical auger segment and displacement elements, in the course of drilling the constituent elements of the tool perform operations on destruction, displacement and soil compaction.

The numerical modeling method has been widely used for defining the parameters of interaction of drilling tools and the soil [1].

The Finite Element modeling of a solid body and elasto-plastic soil interaction is presented in the works by V. V. Aleshin, V. E. Seleznev, G. G. Boldyrev, G. Lacey, E. Susila, S. I. Woo, D. Sheng, J. Walker.

Bolton M. D. studies the possibility of using the software ANSYS, and other programs for solving problems considering the elasto-plastic behavior of the soil [2].



The experiments made by G. G. Boldyrev let us deduce an inference that a better description of the qualitative and quantitative characteristics of the real behavior of the soil can be obtained using the soil model of Drucker-Prager for the static and dynamic models [3].

The works by E. Susila are devoted to substantiation of the finite element model simulating interaction between a conical tip of piles and the soil penetrated. The author suggests using the Drukera-Prager's model to describe physical properties of the soil [4, 5, 6].

In the present work the optimization method of Evolutionary strategy (ES) is used [7]. The mathematical formulation of the optimization problem of the drilling tool can be written as follows:

$$\min F(x), x = (x_1, \dots, x_N) \in X, \quad (1)$$

under the constraint:

$$X = \{x : x_{\min,i} \leq x_i \leq x_{\max,i}\},$$

x – the vector of parameters defining the geometry of the tool; F – the objective functional; X – geometric constraints; x_{\min}, x_{\max} – minimum and maximum values of geometric constraints.

The HDD method involves drilling a pilot hole on a designed path and further enlarging this drill hole. For the optimization problem the stage of enlarging the drill hole diameter from 110 to 150mm is analyzed.

According to the optimization problem the initial geometry of the drilling tool as well as its mode of operation are defined. It is required to determine the optimal geometric parameters of the drilling tool with relation to the chosen criterion of quality that meets the accepted constraints. The schematic construction of the drilling tool is shown in figure 1.

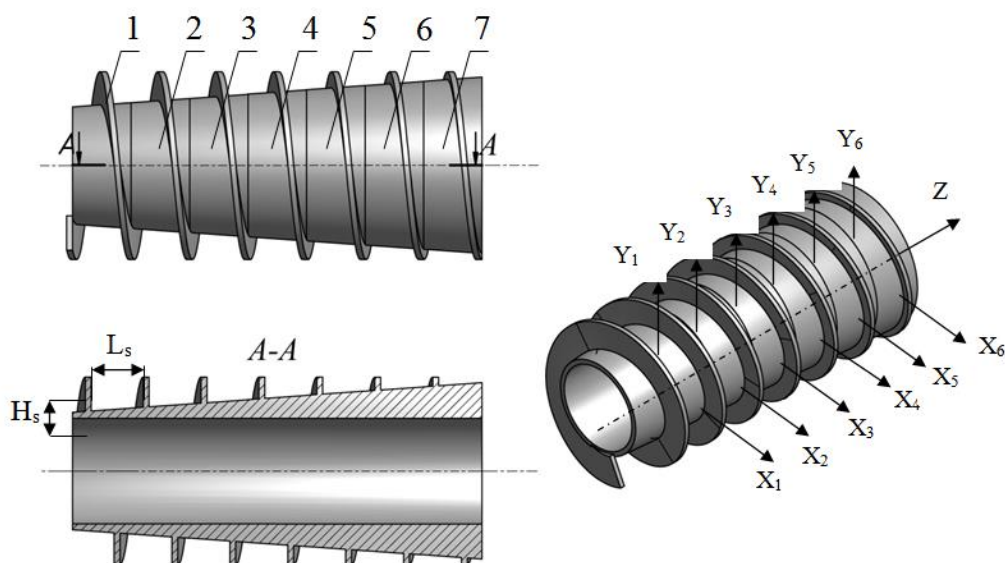

Figure 1. Parameters of the drilling tool: 1 – helical auger segment; 2, 3, 4, 5, 6, 7 – displacement elements

Having studied the interaction of the drilling tool and the soil we can propose a number of geometric parameters to be optimized: helical auger segment (H_s – height of spiral, L_s – length of spiral); the position of displacement elements are relative to the axes X, Y .

In the course of drilling a horizontal hole the drilling tool experiences various loads, which depend on geological conditions and the trajectory of the hole path. In order to accurately determine the force characteristics depending on geometry of the drilling tool, the following simplifications have been specified: the soil material is isotropic, the position of the drilling tool is vertical.

The geometry of the mathematical model is shown in figure 2. The soil is represented by the volume of $500 \times 500 \times 650$ mm ($x \times y \times z$).

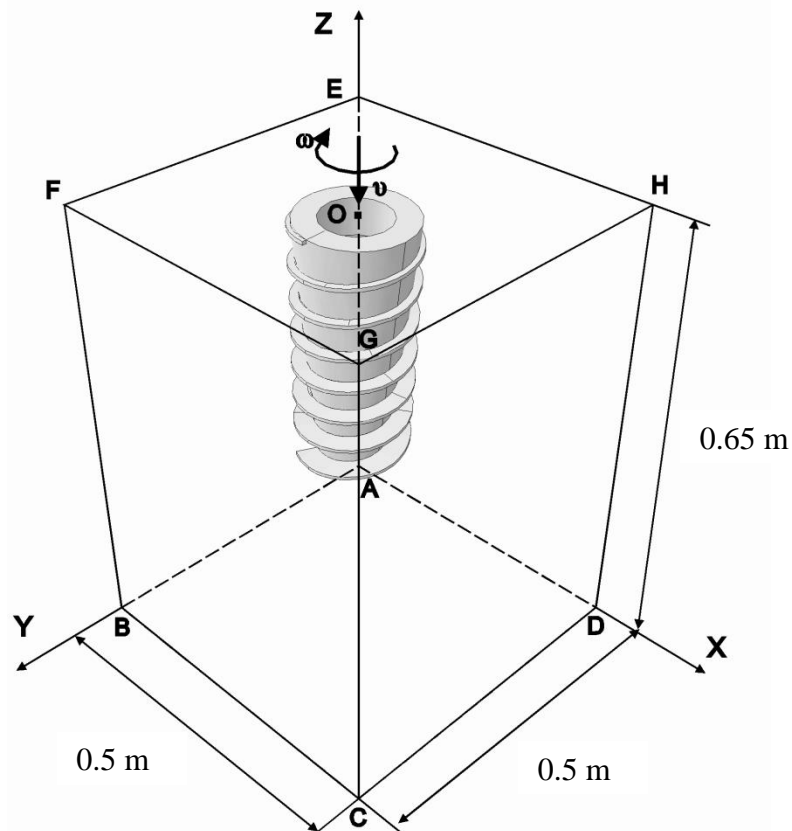

Figure 2. Design scheme of the model

The initial geometry of the drilling tool consists of 1895 finite elements with an average size of a grid $x, y, z - 9$ mm. The reference point of the finite element grid of the drilling tool (node O) is set on the Z-axis, with constant linear velocity $v - 0.1$ m/s and angular velocity $\omega - 120$ rpm.

The output parameter accepted by the corresponding task is the reaction force projected onto the three coordinate axes and torques, R_i and M_i symbols, respectively.

3. Results and discussion

The sample of the drilling tool with the output parameters $R_z = 1.54$ kN, $M_z = 308$ N×m and $F = 1.14$ has the least value of the objective functional from the all sample variants of the drilling tool. A 3D model of the drilling tool with a geometry corresponding to the optimal variant is given in figure 3.

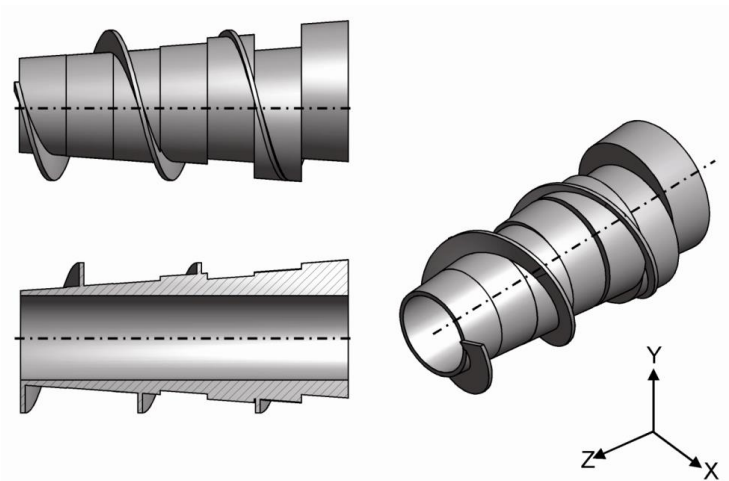

Figure 3. Geometry of the optimal sample

4. Conclusions

1. Based on the study of interaction of the drilling tool and the soil, a number of geometric parameters of the drilling tool are suggested to be optimized.
2. The geometry of the drilling tool providing minimum force characteristics for enlarging the drill hole in the soil by the HDD method has been defined.
3. The influence of geometric parameters of the drilling tool on force characteristics of enlarging the hole has been investigated.

5. References

- [1] Zienkiewicz O C and Taylor R L 2005 *The Finite Element Method for Solid and Structural Mechanics* (Oxford: Elsevier) pp. 631.
- [2] Bolton M D 1986 *Geotechnique*. Vol. **36** (1) pp. 65–78.
- [3] Boldyrev G G and Nikitin E V 1987 *Foundation, foundations and soil mechanics*. Vol. **1** pp. 26–28.
- [4] Jalali J and Vogt N Numerical 2008 *ANSYS Conference & 26th CADFEM Users' Meeting. Darmstadt*. Modelling of Pile Foundation of Noise Protection Walls in Slopes using. pp.1–5
- [5] Susila E and Hryciw R D 2003 *International Journal for Numerical and Analytical methods in geomechanics*. Vol. **27** pp. 585–602.
- [6] Jalali J Numerical 2008 *GeoDACH-Treffen Grainau Deutschland*. Modelling of Single Piles and Pile Groups under Horizontal Loads In: Tagungsband 10. pp. 51
- [7] Moiseev N N, Ivanilov Yu N and Stolyarova E M 1978 *Moscow Nauka. Methods of optimization*. pp. 352