

Influence of long-term storage on fire hazard properties of metal nanopowders

O S Kyrmakova¹, A I Sechin¹ and O B Nazarenko¹

¹Tomsk Polytechnic University, 30 Lenin ave., 634050 Tomsk, Russia

E-mail: olia_917@mail.ru

Abstract. The production and application of nanomaterials is rapidly expanding. Therefore the problem of their properties change during long-term storage becomes essential. The properties of metal nanopowders after long-term storage under ambient conditions were studied and the results are presented in this work. The aluminum, iron, zinc, and copper nanopowders produced by the method of electrical explosion of wires were investigated in this work. The investigation was carried out by X-ray and thermal analysis. The estimation of the flame propagation velocity in the bulk layer of nanopowders was carried out. The characteristics of the nanopowders of nanometals studied are given in terms of their fire hazard. The results can be used for diagnostic of fire hazard of nanomaterials and protection of the enterprises against fire and explosion.

1. Introduction

Nanopowders (NPs) of metals exhibit unique physical and chemical properties and can be used in various industries for production of composite materials, adsorbents for water and gas purification, sensors with high sensitivity and resolution, reagents and catalysts in chemical synthesis, drug carriers in biomedical application etc. [1-5]. When NPs of metals are stored, their properties change under exposure to heat, moisture, light and other factors. The production of metal NPs and their field of application are expanding rapidly, and therefore investigations of the properties of metal NPs, associated with their aging, acquire particular urgency.

One of the methods for metal NPs production is electrical explosion of wires (EEW). This is a nonequilibrium process in which the wire material, as a result of the flow of a powerful pulsed electric current through it, is destroyed with the formation in inert atmosphere of metal nanoparticles [6, 7]. Electroexplosive NPs of metals immediately after production are capable of self-ignition upon contact with air. One of the ways to stabilize NPs is to create an oxide-hydroxide protective coating on the particles by means of the slow intake of air into the discharge chamber [8]. It is known that passivated powders are relatively stable to oxidation during storage and have a high reactivity upon heating.

The aim of this work was to study the effect of long-term storage under ambient conditions on the properties of metal nanopowders obtained by the method of EEW: thermal stability, phase composition, flame propagation velocity in a bulk layer of powders.

2. Experimental

Nanopowders of metals were produced by the method of EEW using the installation described in [6, 7]. Aluminum NPs (obtained by the EEW method in argon Al(Ar) and in a mixture of argon with



nitrogen Al(Ar+N₂)), iron (obtained in argon Fe(Ar)), zinc NP (obtained in argon (Zn(Ar))), and copper NPs (obtained in argon Cu(Ar) and carbon dioxide gas Cu(CO₂)) have been investigated. All the investigated NPs were obtained in year 2000 and stored in air at ambient temperature (20–25 °C).

The thermal stability of the NPs was investigated using a combined TGA / DSC / DTA SDT Q600 thermal analyzer in a linear heating mode (10 °C/min) in an air atmosphere and the temperature range from 20 to 1000 °C. The sample mass was about 5 mg. The phase composition of the powders was determined using an X-ray diffractometer "Shimadzu" XRD-7000. Estimation of the flame propagation velocity in a bulk layer of powders was carried out in accordance with Russian standard GOST 10433-88 "Flame propagation velocity. Appendix 5", for which we created the given configuration and dimensions of the bulk layer of nanopowders, then we ignited it and determined the propagation velocity of the flame front. The device for experimental determination of flame propagation velocity of powders is shown in figure 1. It consisted of a container of triangular cross section with a length of 250 mm (the height of an isosceles triangle was 10 mm, the length of the bottom was 20 mm), two metal plates with a length (250 × 16 × 0.5 mm), and plates of non-combustible material with low thermal conductivity and dimensions of 250 × 20 × 2 mm

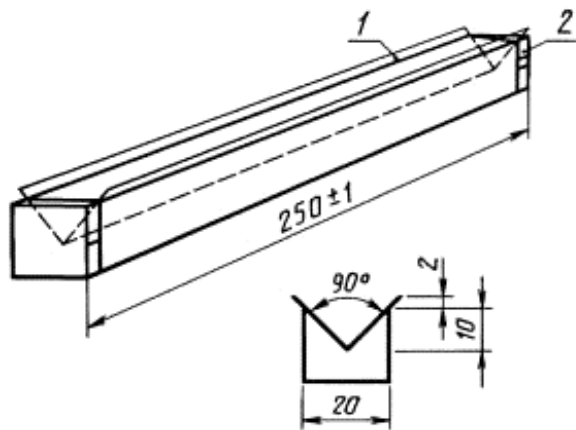

Figure 1. Scheme of device for experimental determination of flame propagation velocity of powders: metal plate (1); container (2).

Measurement of the length of the combustion zone was carried out using a yardstick; the test time was measured using a stopwatch with accuracy class 3. During the experiments, we observed some features in the flame front: the combustion front had an elongated shape along the cross section of the sample, with the difference between the top and bottom. The flame propagation velocity V (mm/s) was calculated by the formula:

$$V = 200/t, \quad (1)$$

where 200 is of the length of the path traversed by the flame front, mm; t is the time, s.

3. Results and discussion

3.1. XRD results

The XRD results are presented in figure 2.

According to obtained XRD data, the presence of oxidized phases (Cu₂O and CuO) is observed only in copper powders. The copper nanopowder was oxidized significantly during long storage in the air due to their high reactivity. The sample Al(Ar+N₂) consists of two crystalline phases: metallic aluminum and aluminum nitride. The samples Al(Ar) and Fe(Ar) consist of metal phase only. The crystalline oxide phases were not detected by means of XRD because of their amorphousness.

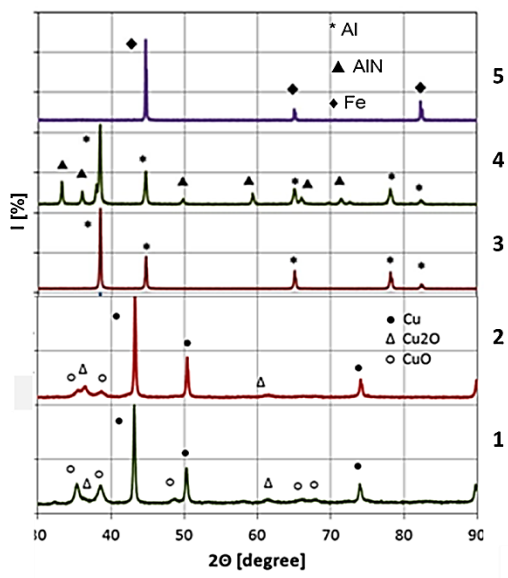

Figure 2. XRD patterns of metal nanopowders: 1 – Cu(CO₂), 2 – Cu(Ar), 3 – Al(Ar), 4 – Al(Ar+N₂), 5 – Fe(Ar).

3.2. Thermal analysis

The results of thermal analysis are shown in table 1.

Table 1. Reactivity parameters of metal nanopowders under non-isothermal heating in air.

Sample	Storage duration (y)	Oxidation onset temperature T_{onset} (°C)	Total mass gain Δm_{tot} (up to 1000 °C) (%)	Thermal effect $\Delta H_{\text{ox tot}}$ (J/g)
Al(Ar)	16	510	61.9	6549
Al(Ar+N ₂)	16	531	48.8	3561
Fe(Ar)	16	180	61.9	9188
Zn(Ar)	16	248	20.3	5448
Cu(CO ₂)	16	234	12.4	750
Cu(Ar)	16	183	9.4	905

The thermal stability of the nanopowders is determined by the state of the surface oxide-hydroxide layer and the conditions for obtaining and storing the nanopowders. For example, the type of preparation medium during EEW process affects the phase composition and activity of the powders upon heating. The activity of the sample Al(Ar+N₂) is lower than that of the sample Al(Ar) because the Al(Ar+N₂) contains less metallic aluminum. The sample Cu(CO₂) is more oxidized than the sample Cu(Ar) and the activity of the Cu(CO₂) is lower.

3.3. Flame propagation velocity

The values of flame propagation velocity are applied in development of measurements for providing fire explosive safety of technological processes. On the basis of test results of the flame propagation velocity in a bulk layer of powders, the characteristics of the studied NPs are given in terms of their fire hazard.

Aluminum Al(Ar) is the combustible fine powder of gray color (figure 3). The material has a cloggy structure that easily breaks down when pressed. In the first second we observed a pronounced stratified combustion in the powder layer. Then, there was an active combustion and its distribution throughout the volume. This was accompanied by a strong glow of the combustion zone and a rapid temperature increase in temperature. In the locations of the cavities an explosive combustion was observed with the scattering of the material. The sample burns to complete burnout. The combustion

products are sintered. The combustion front has an elongated shape along the cross section of the sample, with a difference between the top and bottom of 10–11 mm. The flame propagation velocity value is 11.3 mm/s.



Figure 3. Type of bulk layer of Al(Ar) (a), combustion front (b), combustion products (c).

Aluminum (Al(Ar+N₂)) is the combustible fine powder of gray color (figure 4). In the first second we observed a pronounced stratified combustion in the powder layer. Then, there was an active combustion and its distribution throughout the volume. The sample burns to complete burnout with smoke emission. A strong glow of the combustion zone and a rapid temperature increase in temperature was observed. The combustion products are sintered. The combustion front has an elongated shape along the cross section of the sample, with a difference between the top and bottom of 17–18 mm. The flame propagation velocity value is 4.8 mm/s.



Figure 4. Combustion front of (Al(Ar+N₂)) (a), combustion products (b).

Iron Fe(Ar) is the combustible fine powder of black color (figure 5). It was observed a layered combustion in the powder layer with the spread of the process over the entire volume. The sample burns to complete burnout. In the middle of the sample, glow persists for a long time. The combustion front has an elongated shape along the cross section of the sample, with a difference between the top and bottom of 11–12 mm. During the test, the iron NP is sintered. The flame propagation velocity value is 1.0 mm/s.



Figure 5. Type of bulk layer of Fe(Ar) (a), combustion front (b).

Zinc Zn(Ar) is the combustible fine powder of black color (figure 6). There is a layer-by-layer burning in the powder layer with a change in the color of the sample to a black-coal. The process proceeds without the presence of a visible flame. The sample burns to complete burnout. The combustion front has an elongated shape along the cross section of the sample, with a difference

between the top and bottom of 11–12 mm. During the test, the zinc NP is slightly sintered. The flame propagation velocity value is 0.4 mm/s.



Figure 6. Type of bulk layer of Zn(Ar) (a), combustion front (b).

Copper Cu(Ar) is the low-combustible fine powder of dark color with a reddish tinge (figure 7). A layer-by-layer burning in the powder layer with a weak luminescence is observed and a change in the color of the sample to a black-coal. The sample burns to complete burnout. The combustion front has an elongated shape along the cross section of the sample, with a difference between the top and bottom of 5–7 mm. During the test, the powder is slightly sintered. The flame propagation velocity value is 0.32 mm/s.

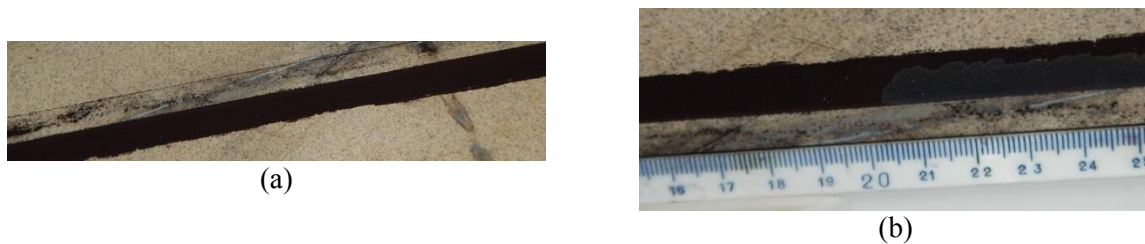

Figure 7. Type of bulk layer of Cu(Ar) (a), combustion products (b).

Copper Cu(CO₂) is the low-combustible fine powder of dark color with a reddish tinge (figure 8). Only in the presence of an ignition source a layer-by-layer burning in a powder layer with a weak luminescence is observed and a change in the color of the sample to a copper one. During the test, this sample is not sintered. The flame propagation velocity is not fixed.



Figure 8. Type of bulk layer of Cu(CO₂) (a), combustion products (b).

The results of estimation of flame propagation velocity for the studied metal NPs are shown in table 2. The data are presented for the samples after their production in 2000 year and after long-term storage in in air at ambient temperature in 2016 year. It can be seen from Table 2 that the measured parameters of the samples Al(Ar) and Al(Ar+N₂) remained practically unchanged. The sample

Cu(CO₂) was highly oxidized during storage as well as the samples Fe(Ar) and Zn(Ar), which led to a significant reduction of the flame front length and flame propagation velocity.

Table 2. The results of flame propagation test.

Sample	Length of flame front (mm)		Flame propagation velocity (mm/s)	
	2000	2016	2000	2016
Al(Ar)	10–10.5	10–11	12.8	11.3
Al(Ar+N ₂)	24–25	17–18	4.4	4.8
Zn(Ar)	22–23	11–12	1.6	0.4
Fe(Ar)	18–18.5	11–12	2.0	1.0
Cu(Ar)	7.5–8	5–7	0.5	0.3
Cu(CO ₂)	6.5–7	–	0.4	–

4. Conclusions

As a result of this study, the fire hazard indicators of a number of metal nanopowders were determined. It was found that changes in the phase composition of metal NPs, which occurred during storage, led to a change in the parameters of the flame propagation velocity. Metal NPs which oxidizes more readily and faster are subject to a greater change: iron, zinc, copper. Aluminum NPs are more resistant to oxidation so they are more active in the combustion process. The obtained results can be used in the developed manufactures and technologies with the use of nanomaterials in order to create safe working conditions.

Acknowledgments

The research is carried out at Tomsk Polytechnic University within the framework of Tomsk Polytechnic University Competitiveness Enhancement Program grant.

References

- [1] Casati R and Vedani M 2014 *Metals* **4** 65
- [2] Ajayan P M 2003 Bulk Metal and Ceramics Nanocomposites *Nanocomposite Science and Technology* Eds P M Ajayan, L S Schadler and P V Braun (Weinheim: Wiley-VCH Verlag GmbH & Co. KGaA) pp 1–75
- [3] Matlochova A, Placha D and Rapantova N 2013 *Pol. J. Environ. Stud.* **22**(5) 1401
- [4] Pestryakov A N, Kolobova E N and Lunin V V 2016 *Int. J. Nanotechnol.* **13**(1–3) 200
- [5] Lah N A C, Samykano M, Trigueros S (2016) *J. Nanomed. Res.* **4**(2) 00086
- [6] Gromov A A, Nazarenko O B, Tikhonov D V, Iljin A P, Pautova Y I 2014 Electroexplosive Nanometals *Metal Nanopowders Production, Characterization, and Energetic Applications* Eds A A Gromov and U Teipel (Weinheim: Wiley-VCH Verlag GmbH & Co. KGaA) pp 67–78
- [7] Kwon Y S, Kim J C, Ilyin A P, Nazarenko O B, Tikhonov D V 2012 *J. Korean Powder Metall. Inst.* **19**(1) 40
- [8] Kwon Y S, Gromov A A, Ilyin A P, Rim G H (2003) *Appl. Surf. Sci.* **211**(1–4) 57