

THIN CONDUCTORS OF rGO IN 2D GRAPHENE OXIDE STRUCTURE

G. Murastov¹, R. Rodriguez¹, A. Lipovka¹, O. Nozdrina¹, M. Bing¹,O. Kanoun², A. Al-Hamry², V. Prakash³, S. Mehta³

Scientific adviser: professor, PhD E. Sheremet*

¹Tomsk Polytechnic University, Russia, Tomsk, Lenina av., 30, 634050²Chemnitz University of Technology, Germany, Chemnitz, Straße der Nationen 62, 09111³Institute of Forensic Science & Criminology, Panjab University, India, Chandigarh, Sector 14, 160014

E-mails: gvm1@tpu.ru, genboysk@gmail.com, *jane.sheremet@gmail.com

In the modern world, portable devices and gadgets have become a significant part of our lives. Smartphones, cellphones, watches with many functions as calls, alerts, calendar; portable players, tablets, thin laptops and ultrabooks – there are a large number of devices that need to be small and energy efficient. And all of these devices need a tiny conductor.

The idea of this research is to develop an alternative technology for creating flexible (*i.e.* efficient and wearable) electronic circuits.

The extraordinary properties of graphene structures are used already to create wearable sensors [1], conductive substrates, *etc.* The required conductor pattern is achieved by removing extra graphene. This creates an empty space between graphene wires. Another way to create complicated circuitry directly under the laser beam is based on graphene oxide. Being modified by laser energy this insulating material starts to conduct electrical current. This process is attributed to the reduction of graphene oxide and requires high temperature annealing [2]. This is one of the most prospective ways of creating conductive channels in two-dimensional materials.

Experimental method and samples. The T1592 P water level sensor from the arduino was selected as a substrate for the deposition of graphene oxide. Previously, the sensor modified by soldering and setting two jumpers. After that, the plate was prepared and consists of 5 pairs of parallel electrodes made of aluminum. The solution of graphene oxide was dropwise deposited at equal distances from the edge of the platform. After ethanol was evaporated the sample was ready for analysis.

The M20 minimarker of Laser Center at Tomsk Polytechnic University (TPU) was used for the purpose of modifying graphene oxide and creating microconductors between two electrodes. The dedicated software was used to control the laser position with 0.1 mm step. The varying speed of the scanning beam and the duration of one pulse are 100-800 mm/s and 20-100 ns, respectively. The pulse repetition rate was fixed at 90 kHz.

The visual detection of ablation was the point determined the mode of operation with a minimarker. This was achieved under the laser beam parameters: 90 kHz, 50 ns, 1% of the nominal power. The bands between the metal electrodes were applied at the same distance.

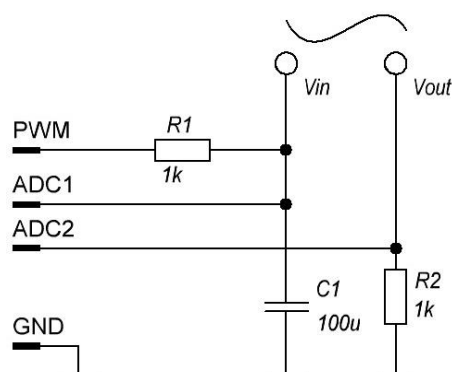

Fig. 1. The electric scheme for the measurement. The sample was connected between V_{in} and V_{out} contacts

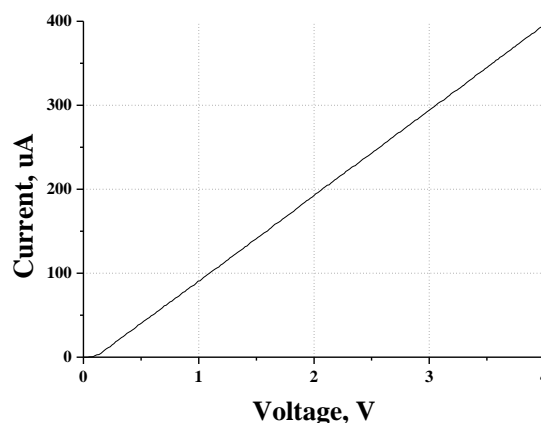

Fig. 2. Data obtained with a 10_kOhm resistor

The circuit measures the volt-ampere characteristics of sample (Fig.1). The Arduino Mega 2560 board has a controller with an 8-channel 10-bit integrated analog-to-digital converter (ADC) for measuring the current in the circuit and 8-bit channels with pulse-width modulation (PWM) for setting voltage on the sample. The

step of changing the voltage is 20 mV, the accuracy of measuring the current equals $\pm 10 \mu\text{A}$. The control measurement was done with a 10 kOhm resistor (Fig.2).

Results and discussion. Without any sample modification, the graphene oxide layer did not conduct any electricity. When creating one or two conducting channels, the measurement was possible with a higher voltage than allowed our scheme or nanoscale current sensitivity. Therefore, 10 channels were created at a speed of laser scanning of 200 mm/s for sample №1 and at a speed of 400 mm/s for sample № 2.

Fig. 3 shows the data obtained from these structures. It turned out that they have an electric channel. A more detailed study made by visual inspection with a digital microscope, allowed us to conclude that the electrons can only move along the tiny edges of the channel where the radiation effect was weaker than at the center of the laser beam. Indeed, at the middle of the laser irradiated patterns we observed the removal of graphene oxide. Apparently, some of the heat is transferred to the surrounding matter as a result of high-temperature heating of the material with its subsequent evaporation in the beam focusing region.

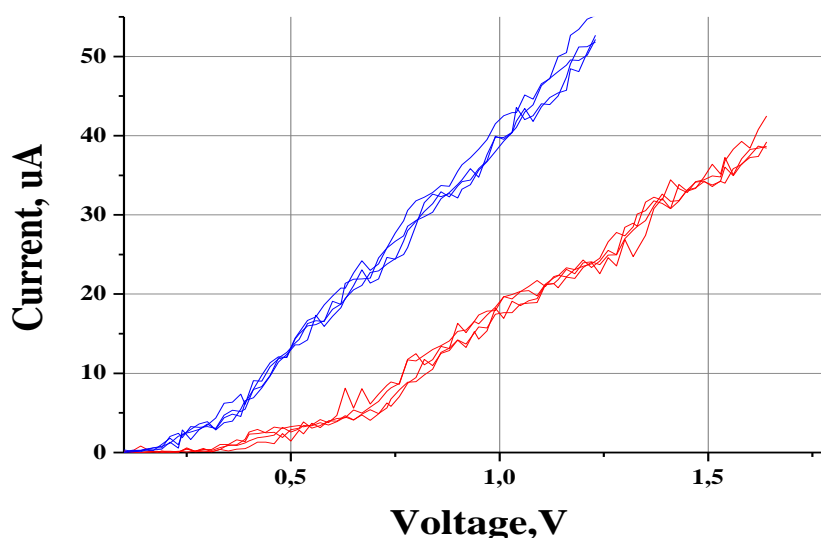

Fig. 3. The volt-ampere characteristics for sample №1 (left) and sample №2 (right).
For one sample for experiment corresponds 4 curves

Conclusion. This work confirms the conclusions of the work by Zhang *et al.* [2] about graphene oxide reduction. Indeed, under the influence of laser radiation it is possible to obtain a conductive channel in a dielectric. Moreover, we found that the conductive channels can be not only thin layers that were directly irradiated by the laser beam, but also outside of the beam focus. Such thin edges can be several orders of magnitude smaller than the laser spot. This technology may help to create nano- and microwires, structures, circuits. Further deeper studies are underway. And finally, this is a cheap and flexible alternative method of electronics production.

LITERATURE

1. Hsin-Liu (Cindy) Kao et al. DuoSkin: rapidly prototyping on-skin user interfaces using skin-friendly materials // Proceedings of the 2016 ACM International Symposium on Wearable Computers. Heidelberg, Germany — September 12 - 16, 2016. p.16-23.
2. Zhang, Y. et al. Direct imprinting of microcircuits on graphene oxides film by femtosecond laser reduction. // Nano Today. – 2010. №5, p. 15–20.