

The stabilization interval system of a tethered descent underwater vehicle

S A Gayvoronskiy, T Ezangina, I Khozhaev and S V Efimov

Department of Automatics and Computer Systems, Tomsk Polytechnic University, 30, Lenina ave., Tomsk, 634050, Russia

E-mail: eza-tanya@yandex.ru

Abstract. To damp the vertical oscillations of a descent submersible caused by dusting the control system utilizing a shock-absorbing hoist located on the submersible was developed. A robust proportional-plus-integral action controller was included in the control loop to ensure acceptable dynamic properties of the system by interval variations of the module mass, the rope length, the equivalent value of stiffness of a spring linkage and the equivalent value of damping factor of the spring linkage. A parametric synthesis of the controller was carried out on the basis of the robust expansion of the coefficient method of the quality rating estimation. The system operability was confirmed by the results of the digital simulation parameters

1. Introduction

At present, there is an active development of the great oceans by stand-alone unmanned submersibles. However, according to [1-3], some real-world problems are still urgent, which are reasonable to solve by means of a tethered descent underwater vehicle (DUV) connected with a ship-carrier by a cable-rope. In accordance with [1-3], engineering, exploration oceanographic and another marine research are conducted by DUV.

The descent submersible during its descent and ascent and by its location close to the sea-bed undergoes some vertical oscillations under the influence of dusting and can become unable to carry out some undersea explorations (DUV can hit the bottom). The possibility of the resonance oscillation due to frequency coincidence of the longitudinal oscillations in the cable with the sea roughness is the most dangerous phenomenon.

The problem of DUV control becomes more complicated since some physical parameters of the control system are precisely unknown or tend to change within certain limits in the process of operation in accordance with laws that are unknown beforehand (the cable parameters, hoist drive parameters, DUV mass).

Therefore, the development of a speed control system of DUV able to damp the oscillation of DUV in the dusting environment and the interval uncertainty of parameters is very urgent. Therefore, the solution of the following problems is of great importance:

- the development of the robust stabilization system structure of DUV with interval parameters;
- synthesis of the robust controller (regulator) capable to maintain system operability under any variations of the cable length and DUV mass;
- DUV control system simulation for the analysis of its dynamic properties.



2. Block diagram of the stabilization system of a submersible

In order to solve the assigned tasks the block diagram of the stabilization system of a submersible, presented in Figure 1 is offered. The system includes two hoists: a boat hoist (BH) located on the ship and intended for DUV descent and ascent and a shock-absorbing hoist (SAH) installed on DUV used to damp its vertical oscillations. The following symbols are introduced in Figure 1: SCTD – sensor of cable tension deviation; CS – comparison-summator, CON – control block, which implements the selected law of control, SS – speed selector.

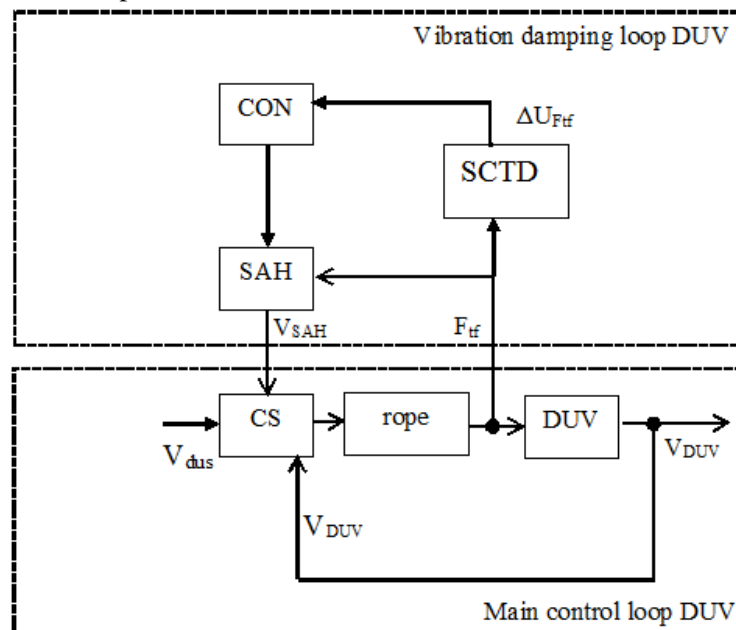

Figure 1. Functional diagram of the DUV stabilization system

The system has a disturbance input (signal V_{dus} – the speed of the vertical vehicle movement under the influence of dusting). An output signal is V_{DUV} – speed of DUV. The intrinsic coordinates of the system are lettered in Figure 1 as follows: V_{sah} – linear speed of SAH; F_{if} – tension force in the rope. SAH installed at a tethered descent underwater vehicle is used to compensate for the sea oscillating motions.

In this mode the tension deviation from the set value corresponding to the DUV weight is measured by a sensor of cable tension deviation. The output signal of the sensor passes to the SAH controller.

Let us write down the equations of separate system components. The block diagram is arranged on the basis of these equations. The equation of the vertical movement of the tethered submersible vehicle is as follows:

$$m \frac{dV_{DUV}}{dt} = F_{if},$$

where m is mass of the tethered submersible vehicle. The inclusion of the resilient member of quasi-zero stiffness in the rope linkage between the ship and the tethered submersible vehicle allows considering the stiffness of the resilient member as equivalent stiffness. The damping of the resilient member will be determined in the same way as the damping of spring linkage. The equation of spring linkage is obtained on the basis of Hooke's law.

$$F_{if} = C((x_{dus} + x_{bh}) - (x_{sah} + x_{tsv})) + \chi \frac{d((x_{dus}) - (x_{sah} + x_{tsv}))}{dt},$$

where C is an equivalent value of stiffness of the spring linkage, which is equal to the stiffness of the resilient member, χ is an equivalent value of the damping factor of the spring linkage, which is equal

to the damping of the resilient member, x_{dus} is a vertical movement of the ship, x_{SAH} is a movement of the rope on the drum of SAH, x_{tsv} is the vertical movement of the tethered submersible vehicle. The electric drive of SAH is described by the following equation:

$$J_2 \frac{d\omega_{sah}}{dt} = M_d + M_{if},$$

where J_2 is a moment of SAH inertia, ω_{sah} is angular velocity of the drum rotation of SAH, M_d is a controlling torque of the SAH drive, M_{if} is a torque produced on SAH by the rope tension force. Thus,

$$M_d = k_{m2}(U_c - U_e),$$

where k_{m2} is the transfer constant of SAH drive per torque, U_c is the output voltage of the SAH controller, $U_e = k_{e2}\omega$ is a reverse electromotive force (EMF) voltage of the SAH drive, k_{e2} is a reverse EMF coefficient of the SAH drive, R_2 is a drum radius of SAH. The mathematical description of a BH electric drive is similar to the description of the SAH drive. The analysis of the transfer function of the speed feed forward control system of DUV under the steady-state conditions with different W_{con} has shown that it is reasonable to use a controller which ensures the astaticism of the first order in the system. Its transfer function can be presented as follows:

$$W_{con}(s) = (k_1 + k_2s) / s.$$

The given controller has two setting parameters k_1, k_2 , determining the quality of the transient processes in the system. Thus, the block diagram of the system obtained on the basis of the above mentioned mathematical description is illustrated in Figure 2. The system has the following constant parameters [1]: $K_{m2}=0,3$ (Nm/A); $K_{e2}=1$ (Vs/rad); $J_2=0,5$ (kgm²); $R_2=0,1$ (m) and interval parameters $\chi = [35; 200]$ (Ns/m); $C = [800; 4.25 \times 10^3]$ (N/m); $m_{DUV} = [4.47 \times 10^3; 4.65 \times 10^3]$ (kg); $l = [2; 10]$ (m).

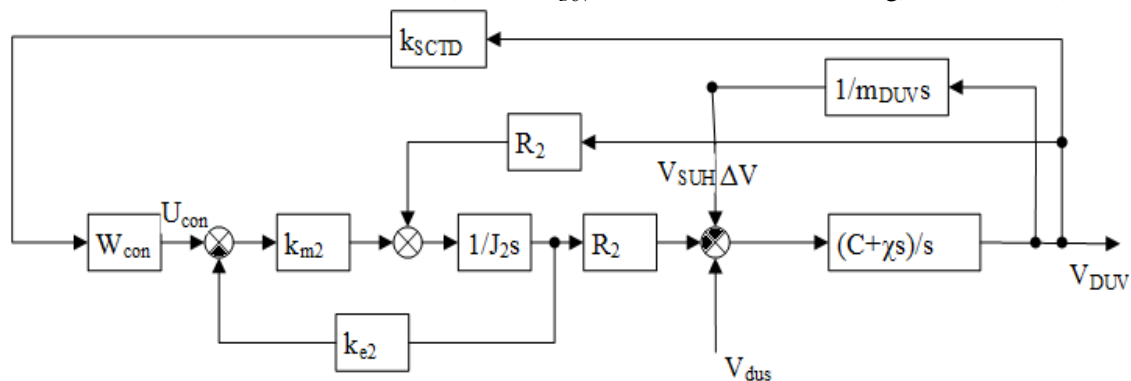

Figure 2. Structure diagram of the DUV stabilization system

The differential equations corresponding to the block diagram shown in Figure 2 are as follows:

$$A(s) = [a_{33}]s^3 + [a_{23}]s^2 + [a_{13}]s^1 + [a_{03}], \quad (1)$$

where

$$[a_0] = [C]k_{m2}(k_{e2} + [m_{DUV}^*]R_2k_{sctd}k_1);$$

$$[a_1] = [C]R_2[m_{DUV}^*](k_{m2}k_{sctd}k_2 + R_2) + [C]J_2 + [\chi]k_{m2}(k_{e2} + R_2[m_{DUV}^*]k_{sctd}k_1);$$

$$[a_2] = [m_{DUV}^*]k_{m2}k_{e2} + [\chi]J_2 + R_2[m_{DUV}^*][\chi](R_2 + k_2k_{sctd}k_{m2});$$

$$[a_3] = J_2[m_{DUV}^*].$$

As it is shown in (1), the polynomial coefficient includes linearly the controller settings and multilinearly the interval system parameters. Due to availability of the interval-undetermined parameters in the system it is necessary to impart this system some robust properties ensuring the

preservation of a permissible performance quality at any possible variations of unstable parameters [4]. It is suggested that one should apply a robust approach by the parametric synthesis of PI-controller in the control loop of SAH ($k_1 = 0.078$, $k_2 = 0.079$).

3. Control process simulation

To test the operability of the robust stabilization system of DUV with a synthesized proportional - integral (PI) –controller, let us carry out its mathematical model in Matlab by means of Simulink appendix. In the simulation we used the model of dusting, which is maximally close to real conditions. A block diagram of this model is shown in Figure 3.

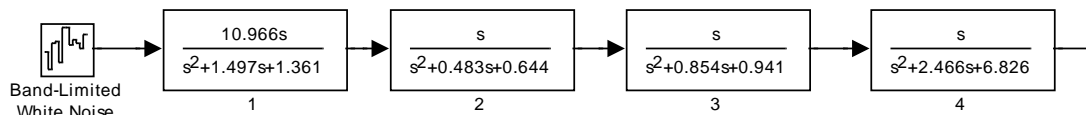

Figure 3. Block diagram of a dusting model

The analysis of the robust stabilization system of DUV has shown that by any possible values of the interval parameters of the system the amplitude of speed fluctuation V_{DUV} is insignificant under the impact of the dusting, and its maximum is 4×10^{-3} m/s (Figure 4, a). We can conclude from Figure 4 (b) that if the stabilization system of DUV is not utilized, the amplitude of speed fluctuation V_{DUV} is significant and is equal to the amplitude of vertical movement of the watercraft in the dusting environment.

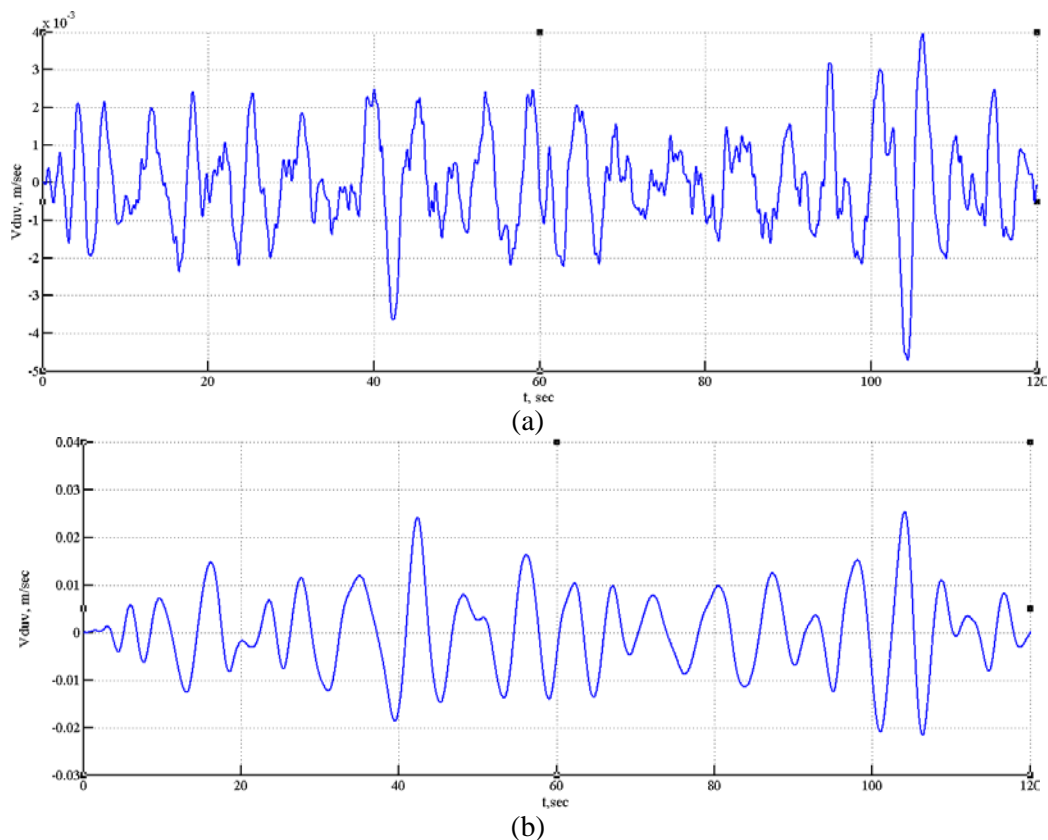

Figure 4. Diagrams of the speed fluctuation of the DUV vertical movement in the descent mode (a) the robust stabilization system is utilized; (b) the stabilization system of DUV is not utilized

Thus, the suggested block diagram of the robust stabilization system of DUV and the technique of the parametric synthesis of the robust PI – controller settings enable a solution of the problem associated with oscillation damping of DUV in the marine roughness environment and variations of the system parameters.

4. Conclusion

The robust stabilization system of DUV that enables compensation of the influence of the ship-carrier rocking by descent and ascent of DUV as well as passing near the sea-bed was developed in the given article. To adjust the interval parameters of the PI- controller used in the system, the interval expansion of the coefficient method and the criterion of a maximum robust degree of stability were applied. The operating efficiency of the designed system was confirmed in Matlab by the results of its simulation under different modes of the operation corresponding to the boundary values of the interval parameters of the system.

Acknowledgments

The reported study was partially supported by RFBR, research project No 14-08-31031.

References

- [1] Nam B W, Hong S Y and Kim Y S 2013 *International Journal of Offshore and Polar Engineering* **23(1)** 33–37
- [2] Rowe S, Mackenzie B and Snell R 2001 *Proceedings of the 10th Offshore Symposium* 1–9
- [3] Neupert J, Mahl T, Haessig B, Sawodny O and Schneider K 2008 *American Control Conference* 538–543
- [4] Ezangina T A and Gayvoronskiy S A 2014 *Advanced Materials Research* **1016** 394–399