

The peculiarities of CVD diamond coatings synthesis in abnormal glow discharge plasma using repetitively-pulsed mode

S A Linnik, A V Gaydaychuk and V V Okhotnikov

National Research Tomsk Polytechnic University, 30, Lenin Avenue, 634050, Tomsk, Russia

E-mail: stepan_lin@mail.ru

Abstract. We report about the features of polycrystalline diamond coatings CVD synthesis in repetitively-pulsed plasma of abnormal glow discharge. The discharge burning time was varied from 0.5 to 10 ms with proportional pauses. The dependences of deposited diamond films growth rate on the durations of the discharge burning and pauses are presented. The mutual influence of two plasma filaments on each other and onto the substrate has unequivocally established. Raman spectroscopy, X-ray diffractometry and SEM were used for identification of phase composition and microstructure of deposited films. Implementation simplicity and reliability of the proposed discharge system may find application in diamond film deposition industries.

1. Introduction

The increase in CVD diamond films growth rate is the subject of intensive research around the world because of their unique characteristics, such as hardness, wear resistance, chemical inertness and thermal conductivity [1-3]. Despite the fact that all diamond CVD reactors are based on the same principles, each particular reactor type has its own deposition rate, applied power, working pressure and other parameters. Among the various diamond films deposition methods, there are those such as microwave plasma (MPCVD) [4], hot filament (HFCVD) [5], arc-jet [6] and glow discharge [7,8] CVD. Among the other methods, glow discharge CVD is considered to be one of the most effective diamond deposition method because of its simplicity, high growth rate (up to 10 $\mu\text{m/h}$ [9,10]) and scalability.

In last papers [9,11], we described the construction of a new AC abnormal glow discharge CVD system based on one plasma line, which enabled the deposition of diamond films on the substrate sized 35x200 mm. But the problem of construction of the glow discharge CVD reactor with several plasma lines is still topical, due to the lack of data on the mutual influence of several plasma lines.

In this paper, we report about the peculiarities of CVD diamond coatings synthesis in two AC abnormal glow discharge plasma lines discharge system using repetitively-pulsed mode. The discharge characteristics and the system construction are described. The structure, phase composition and growth rates of produced diamond films are examined. The mutual influence of two plasma lines on each other and onto the substrate has unequivocally established.



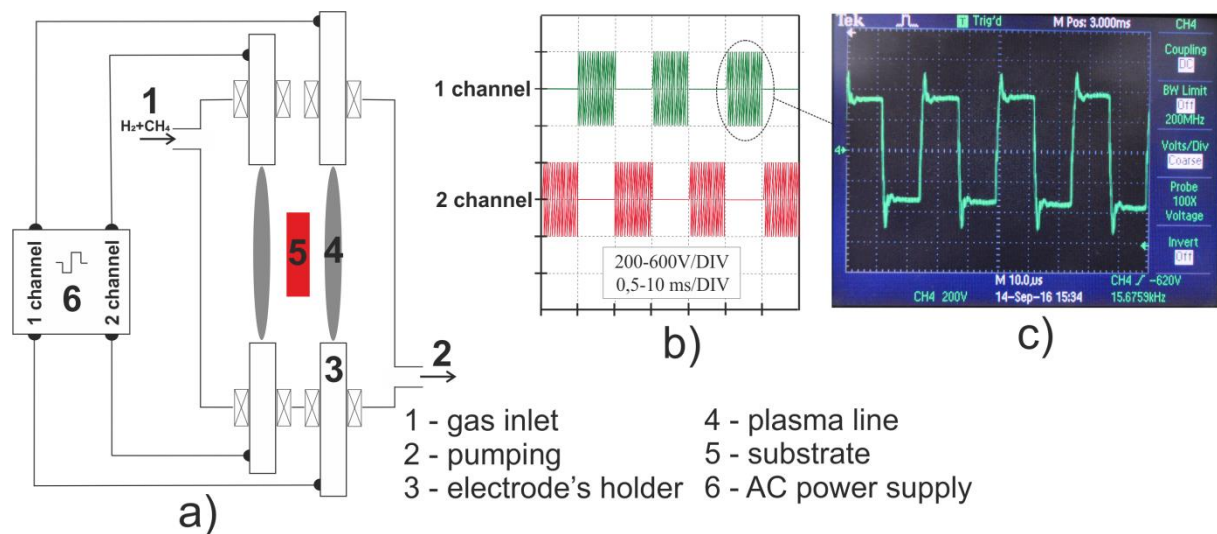

Figure 1. Scheme of the experimental arrangement (a), combined time-voltage diagram of two plasma lines burning (b) and voltage oscillogram of one channel (c).

2. Experimental

Figure 1 shows the scheme of the experimental setup for diamond film deposition in AC glow discharge using two plasma lines. The plasma lines burning mode could vary from parallel (both plasma lines were working simultaneously without interruption) to repetitively-pulsed type (plasma lines were working alternately with a frequency of channel switching from 50 to 1000 Hz). The waveform of each channel burning voltage was represented (as in work [9]) with unipolar rectangular pulses and a short igniter voltage impulse at the initiation of each pulse.

In our experiments the power supply with the operating current up to 20 A and voltage up to 1000 V was used. The amplitude of ignition pulses reached 1.2 kV. The discharge system consisted of four cooled electrode holders, in which the electrodes made of tungsten were fixed. The spacing between two plasma lines also could be varied in the range from 20 to 100 mm, and the interelectrode distance could reach as much as 20 cm. The gas mixture with methane content from 3 to 6 % (be the volume flow) was used as a working atmosphere. The total flow rate of the precursor gasses could change from 50 to 300 ml/min. The substrates (molybdenum rods and plates) were placed on the cooled substrate holder between the plasma lines. The pressure in the deposition chamber could range from 20 to 100 Torr and it was controlled by a diaphragm gauge (Televac 1EP/N). The substrate temperature during deposition was maintained at 850 ± 25 °C using an IR pyrometer. During the deposition substrates were at ground potential.

The surface morphologies and phase composition of the films were analyzed by scanning electron microscopy (SEM) using an FEI Quanta 3D SEM without the sputtering of any conductive film. The samples were characterized by X-ray diffraction (XRD) using Cu - K α radiation on a Shimadzu XRD-6000 diffractometer. Raman spectra were recorded on a NanoScan Technology Centaur I HR spectrometer.

3. Results and discussion

Figure 2 illustrates that discharge behavior strongly depends on the frequency of channels switching, but the discharge is stable at frequency of 50 Hz as well as at 1 kHz. At low pressures in CVD reactor (less than 25 Torr) the volume form of discharge between each pair of electrodes occurs, and electrodes do not have a significant influence on each other (see figure 2a). At higher pressures, the discharge is constricted in the cord (plasma line) (see figure 2b-g) and its behavior changes significantly. Plasma lines begin to exert the influence on each other with decreasing of downtime (i.e.

effectively by increasing the frequency of channel switching). It is expressed in bending of the plasma lines towards each other (see figure 2d). The reason of this can be high temperature gas area (and therefore with lower dielectric strength) which generated with discharge plasma. It is clear that lifetime of this area continues for some time after the extinction of the discharge.

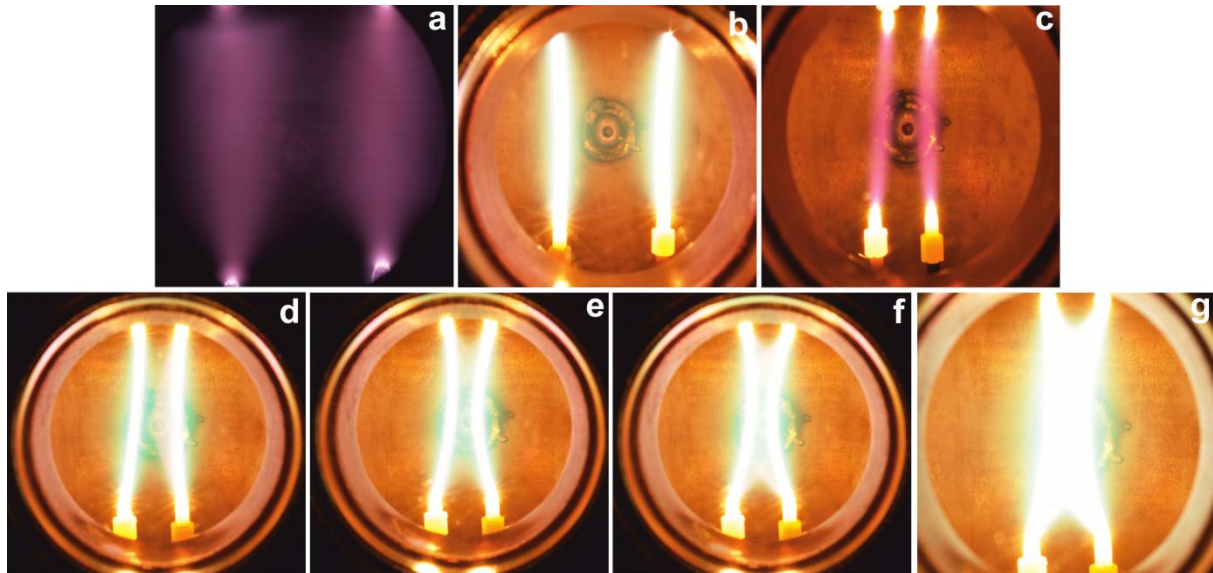

Figure 2. Colour photographs of two plasma lines burning taken through the viewport: (a) volume discharge at 20 Torr in pure hydrogen at a switching frequency of 1 kHz, (b) constricted discharge at 60 Torr in H_2/CH_4 atmosphere at a switching frequency of 100 Hz, (c) constricted discharge at 40 Torr in pure hydrogen at a switching frequency of 100 Hz, (d) increasing interconnection between plasma lines at a switching frequency of 300 Hz (60 Torr; H_2/CH_4 atmosphere), (e) more significant interconnection between plasma lines at a switching frequency of 500 Hz (60 Torr; H_2/CH_4 atmosphere), (f) at 700 Hz, (g) at 1 kHz.

For a while after first plasma line attenuation the second plasma line can be more easily ignited not in a straight line between electrodes (the shortest distance), but in a curved arc towards the plasma line. As a result, at high frequencies of channel switching (i.e. in a state approaching a parallel mode of combustion) the common combustion region is formed (see figure 2f,g). It represents a superposition of two plasma lines. This phenomenon may be very useful for the development of CVD reactors for large area deposition on the flat area of substrates (because the uniformity of the coatings will increase with combining of plasma lines), but in this case the deposition on milling tools (3D substrate) can be problematic.

Since the main purpose of this discharge system is the deposition of diamond coatings we conducted a series of experiments on the deposition of these coatings on the samples of various shapes and sizes with different frequency of channel switching. As a result it was found that in a pulsed mode the optimal gas atmosphere for sustained diamond growth is similar to a parallel mode of plasma combustion (methane content must be no more than 10 %). Any correlation of this parameter on the switching frequency was not observed. At the same time, it was found that the deposition rate in a pulsed mode, essentially the same as in the parallel mode of combustion, despite the half as much power consumption (calculated to one plasma line). Table 1 shows the main deposition parameters of CVD diamond films, obtained in different discharge modes (50 Hz, 500 Hz, 1 kHz). It is seen that the difference in deposition rates comparable to the error in the measurement of the substrate temperature (which directly influences the deposition rate). This fact of the absence of the effect of reducing the power input to the discharge on the coating deposition rate is quite atypical. For example for

microwave CVD reactors the direct correlation between the deposition rate and increasing the injected power was observed [12]. This phenomenon can be explained by different mechanisms and intensities of active radical generation in an anomalous glow and microwave discharges. In the

Table 1. The deposition parameters of CVD diamond films obtained in different discharge modes.

Discharge mode	Discharge power per one plasma line, W	Reactor pressure, Torr	H ₂ /CH ₄ ratio	Substrate temperature, °C	Diamond film growth rate, μm/h
Constant (40 kHz without modulation)	5.5	60±1	50:3	850±25	7.5±0.2
50 Hz modulation	2.75	60±1	50:3	850±25	7.0±0.2
500 Hz modulation	2.75	60±1	50:3	850±25	7.1±0.2
1000 Hz modulation	2.75	60±1	50:3	850±25	7.4±0.2

plasma line (quasiarc discharge) the area with very high temperature (over 5000 °C) is generated, while the temperature in microwave discharge plasma under the same pressure does not exceed 2500 °C [13]. At higher temperatures more active particles (radicals, unstable molecules) required for diamond gas phase growth are generated [14] and lifetime of such particles after discharge attenuation also directly depends on the temperature.

Figure 3a shows the SEM images of the 25 μm textured diamond film with well-faceted microcrystallites without amorphous non-diamond impurities. Therefore, to determine a change in the phase composition of the film surface at different stages of deposition, Raman spectra were obtained (see figure 3b). The typical Raman lines of diamond and amorphous (sp²) carbon (1332 cm⁻¹ and 1450 cm⁻¹) are observed. The XRD diffractogram obtained from the front surface of the diamond films is shown in figure 3c. It contains crystalline diamond diffraction peaks at 44.0, 75.5 and 91.8°, corresponding to the {111}, {220} and {311} planes, respectively. There are no lines of other phases which confirms the purity of the diamond film.

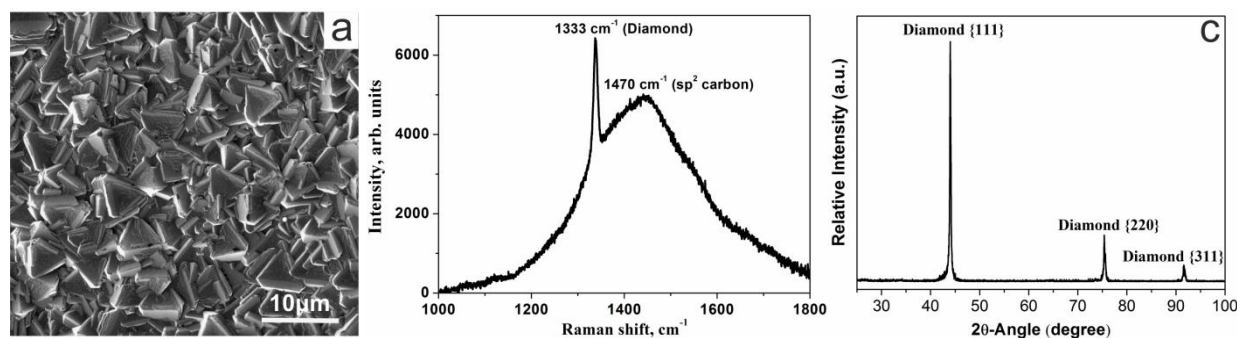

Figure 3. The data about structure and phase composition of obtained diamond coatings: SEM image of 25 μm film (a), Raman spectra (b) and x-ray diffraction pattern (c).

4. Conclusion

We consider the features of polycrystalline diamond coatings CVD synthesis in repetitively-pulsed plasma of abnormal glow discharge. The discharge burning time was varied from 0.5 to 10 ms with proportional pauses. The dependences of deposited diamond films growth rate on the durations of the discharge burning and pauses are presented. The mutual influence of two plasma filaments on each other and onto the substrate has unequivocally established. Raman spectroscopy, X-ray diffractometry and SEM were used for identification of phase composition and microstructure of deposited films. Implementation simplicity and reliability of the proposed discharge system may find application in diamond film deposition industries.

References

- [1] Williams O A 2001 *Diam. Relat. Mater.* **20** 621
- [2] May P W 2000 *Philos. Trans. R. Soc. Lond. A* **358** 473
- [3] Seelmann-Eggebert M, Meisen P, Schaudel F, Koidl P, Vescan A, Leier H 2001 *Diam. Relat. Mater.* **10** 744
- [4] Liang Q, Yan C, Lai J, Meng Y, Krasnicki S, Shu H, Mao H, Hemley R J 2014 *Cryst. Growth Des.* **14** 3234
- [5] Matsumoto S, Sato Y, Kano M, Setaka N 1982 *Jpn. J. Appl. Phys.* **21** 182
- [6] Han Q Y, Or T W, Lu Z P et al 1991 *Proceedings of the Second International Symposium on Diamond Materials* **91** 115
- [7] Chae K –W, Baik Y –J, Pack J –W, Lee W –S 2010 *Diam. Relat. Mater.* **19** 1168
- [8] Suzuki K, Sawabe A, Yasuda H et al 1987 *Appl. Phys. Lett.* **50** 728
- [9] Linnik S A, Gaydaychuk A V 2013 *Diam. Relat. Mater.* **32** 43
- [10] Linnik S A, Gaydaychuk A V 2014 *Vacuum* **103** 28
- [11] Linnik S A, Gaidaichuk A V 2012 *Tech. Phys. Lett.* **38** 258
- [12] <http://sekidiamond.com/microwave-plasma/products/AX6600.html>
- [13] Hassouni K, Grotjohn T A, Gicquel A 1999 *J. Appl. Phys.* **86** 134
- [14] Corat E J, Goodwin D G 1993 *J. Appl. Phys.* **74** 2021

Acknowledgments

This work was supported financially by Russian President's grant № MK-5516.2016.8 and by the Russian Foundation for Basic Research (research project № 16-32-60018 Mol_a_dk).