

The study of initial permeability temperature dependences for LiTiZn ferrite ceramics

A B Petrova¹, A L Astafyev², A V Ershov³

¹Junior Researcher, Tomsk Polytechnic University, Tomsk, Russia

²Engineer, Tomsk Polytechnic University, Tomsk, Russia

³Undergraduate, Tomsk Polytechnic University, Tomsk, Russia

E-mail: abk9@tpu.ru

Abstract. Results of obtaining and analyzing the temperature dependences of initial permeability of ferrite ceramics are presented in the paper. It was shown that the level of the defective state of ferrite ceramics can be obtained from the value of two parameters α and β of the phenomenological expression describing the experimental dependences. The results showed that the main criterion of the defect state is the parameter β/α , which is related to the elastic stresses in the material. An indicator of the structure perfection is also the value of the maximum of the initial permeability near the Curie temperature.

1. Introduction

Ferrite ceramics of the lithium group are the materials with well-established magnetic properties [1–3]. At present, in the manufacture of ferrite products, there are various defectiveness controlling methods, based on measuring those properties of the material that appreciably react to changes in chemical composition. These are methods for measuring the true heat capacity, saturation magnetization, and magnetic permeability in the temperature interval including the Curie point, the initial paraprocess susceptibility. Such methods are laborious, selective to certain defects types and are low-sensitivity.

Nowadays microwave ferrites are widely used as magnetic materials for phase shifters, circulators, phased array elements and other microwave technology elements. In the process of their manufacture according to the classical ceramic technology, the probability of a residue of unreacted oxides and phases of the synthesis reaction intermediate products is high. Such defects, along with the material porosity, cause the deterioration of its magnetic characteristics [2].

Therefore, for ferrite ceramic products it is required to develop a modern highly sensitive magnetic method for controlling the structural perfection (defective state) of the resulting material. The base of this method can serve as a measure of the temperature dependence of the ferrite ceramics initial permeability. Such dependences are one of the most structurally sensitive and serve to determine the phase homogeneity of ferrites and to determine their Curie point. To optimize new technological processes, an operative control of the whole set of defects that affect the magnetic parameters of ferrite ceramics is necessary.

The use of structurally sensitive characteristics for studying the chemical inhomogeneity of ferrite materials has shown that quantitative comparisons of homogeneity and defect state of materials are possible only in the presence of approximating expressions for the controlled parameters temperature dependences. In work [4], a phenomenological expression for the temperature dependence of initial permeability $\mu_i(T)$ was obtained. In ferrite physics, the most of papers related to temperature studies of the initial permeability and susceptibility were devoted to the study of the impact of additives or



regimes of sintering ceramics on the Curie point. In modern works devoted to the study and analysis of the temperature dependences of the ferrites magnetic properties, the impact of homogeneity on the drop sharpness in the temperature dependence of initial permeability near the Curie point was pointed out [5, 6].

The maximum value of the initial permeability – μ_{max} , was determined from the maximum of the temperature dependence μ_i .

Initial permeability has been found to be related with magnetization and ionic structure, thereby the thermal spectra of permeability can be also considered as a test of the formation and homogeneity of the ionic structure of the samples. The present work reports the results of approbation of the method for estimating the defective state of ferrite ceramics on the basis of mathematical processing of the temperature dependence of initial permeability.

2. Experimental techniques

The sintering process and specimen preparation method were the same as reported in [7–10]. The specimens were manufactured using a standard ceramic production process from an industrially synthesized mixture (Russian designation of the grade “3ZSC-18”) by thermal sintering of the compacts in air in a laboratory resistance furnace at the temperature 1423 K for one hour. The mode of sintering was selected to follow that used in the industrial production of the 3ZSC-18 ferrite.

The compaction of toroidal shape samples was carried out using one-sided cold pressing with a hydraulic press PGr-10. The pressure was 200 MPa. Pressure impact time interval was three minutes.

The samples were sintered in laboratory conditions in air in a resistance furnace with a built-in thermostat. For approbation of the method for estimating the defective state of ferrite ceramics, samples were sintered in laboratory conditions from charge synthesized by ceramic technology. The sintering regime parameters was $T_s = 1150$ °C, $t_s = 1$ h. After sintering, the toroidal shape samples possessed the following dimensions: 18.5×14×2 mm.

In present work ceramic samples density and porosity were measured by hydrostatic weighing with high-precision analytical balances Shimadzu AUW 220D.

Electron micrographs were obtained using scanning electron microscope Hitachi TM-3000. The average grain size was calculated by the intercept method.

The saturation magnetization (M_s) was measured at room temperature with the vibrating sample magnetometer with the maximum field of 10 kOe.

The phase composition of the samples was controlled using an ARL X'TRA X-ray diffractometer (Switzerland) with a Peltier Si(Li) semiconductor detector and $\text{CuK}\alpha$ radiation. XRD patterns were measured for $2\theta = (10 - 80)^\circ$ with a scan rate of 0.02 °/s. The phase composition of the examined samples were determined using the PDF-4 powder data base of the International Centre for Diffraction Data (ICDD). The XRD patterns were processed by the full-profile Rietveld analysis using the Powder Cell 2.5 software.

The reference material of the ferrite ceramics of grade 3CH-18 (SL-187) had the toroidal shape (outer diameter $D = 20.5$ mm, internal diameter $d = 10.9$ mm, height $h = 3.5$ mm). They were purchased at the Ferrit-Domen Research Institute for comparative studies of the temperature dependences of initial permeability. For reference material the following sintering regime was used: $T_s = 960$ °C, $t_s = 8$ hours.

For measuring the temperature dependences of initial permeability, an installation on the basis of an automatic bridge LCR-819 (digital meter L, C, R) and a special measuring cell with a built-in heater was constructed. The frequency of the magnetizing field was 10 kHz. The level of the test signal was 0.05 V.

The assembled device used a heating cell (Figure 1) of the original design. The measuring cell represents a stainless steel cylinder 1. At the top, the cylinder closes with a fluoroplastic lid 2 with a sample fixing device 3 and a thermocouple 4. The cover also had apertures for the output of the conductors 5 from the winding of the measured sample 7. In the lower part of the cylinder, to equalize the temperature in the sample area, was fixed a copper cup 11, at the bottom of which there is a heater

8. For increasing the heating uniformity, the upper part of the copper cup was closed with an aluminum heat shield. All the elements were located in an aluminum case 10, on which there are connectors for connecting the ground wire and the wires supplying the heating element. The case was thermally insulated from the cell heating parts by a powder of light-weight fireclay bricks 9.

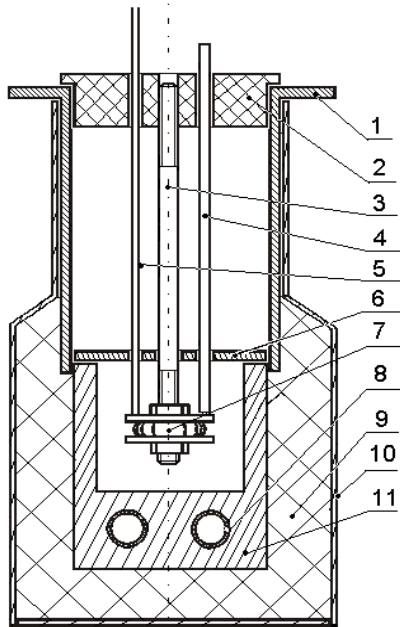

Figure 1. Measuring cell: stainless steel cylinder (1), fluoroplastic lid (2), lower electrode with sample fixing device (3), thermocouple (4), conductors (5), thermal screen (6), sample (7), heater (8), powder of light-weight fireclay bricks (9), aluminium case (10), copper cup (11).

A single-layer winding was wound on the sample from 46 turns of the MG TF-0.12 wire with fluoroplastic insulation, which retains its properties up to the upper limit of the measurements. The sample with the winding was fixed inside the measuring cell. The ends of the winding through the holes in the cover were taken out to the connection device of the automatic bridge (LCR-819). The heating of the measuring cell was made by a built-in heater. The current in measuring cell in was set by a thermocontroller. The thermostat was powered from the transformer. The temperature was controlled by a thermocouple of the chromel-alumel group. Thermocouple junction was pressed against the sample.

Toroid samples were used as the cores of the inductance coil. The inductance L was measured by a bridge method for an inductor with a core of a ferrite toroid. The measurement of L was carried out on a low-frequency meter LCR-819 in an electromagnetic field with a frequency of 1 kHz with an intensity of 0.1 Oe. A ferrite toroid with a winding from one layer of a thin copper wire with fluoroplastic insulation was placed in a special measuring cell with built-in heaters. The measurements were carried out with a slow cooling of the sample from a temperature 50 degrees higher than the Curie point, in order to exclude the influence of the prehistory on the initial permeability. The temperature was controlled by a thermocouple of the chromel-alumel group (type K). Thermocouple's measuring junction was pressed against the sample. Installation on the basis of an automatic bridge LCR-819 and a voltmeter V7-78/1 was constructed to measure the temperature dependence of initial permeability. The installation provided automated measurements of the inductance and temperature of the sample with a given polling rate. Thus, it allowed specifying a different number of measured points and thereby setting the measurement resolution. The latter condition was required to refine the complicated dependences $\mu_i(T)$ for samples with two or more magnetic phases, and for samples with Hopkinson peak. The data from the LCR-819 (L) meter and V7-7/1 (T) voltmeter were received as a text file on a PC using a specially written module of the LABView software package. The calculation of $\mu_i(T)$ and their mathematical processing was carried out using the Origin 9.

The initial permeability (μ_i) of the toroidal ferrite samples was calculated by using the Equation

$$\mu_i = \frac{L \cdot 10^7}{2 \cdot h \cdot N^2 \cdot \ln(D/d)} \quad (1)$$

where L – inductance coil (H); N – number of turns in a coil; h – toroid height (m); D , d – outer and inner diameter of toroid (m).

The Curie point T_c was determined from the temperature dependence of μ_i by making a tangent to the curve of the rapid drop section of μ_i . The intersection of this tangent with the temperature axis determined the value of T_c . Also T_c was determined by mathematical processing $\mu_i(T)$.

3. Result and discussion

Figure 2 presents a microstructure of the sintered ferrite ceramics surface.

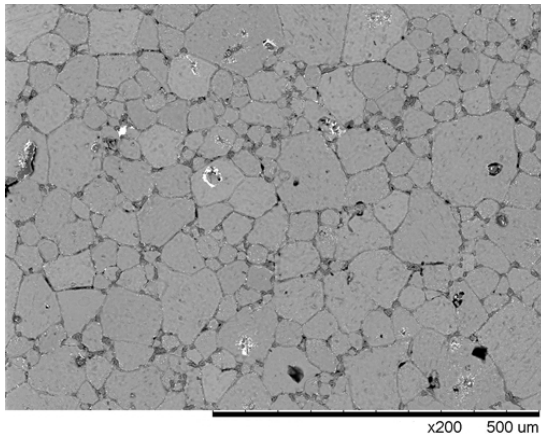

Figure 2. SEM micrograph of ferrite ceramics laboratory sample.

As can be seen from the Figure 2 ferrite is characterized by a typical polycrystalline structure with grains and grain boundaries. As can be seen from the Figure 2, the average grain size is in the range of 30–150 μm .

Samples sintered under laboratory conditions and those manufactured by Ferrit-Domen Co were used to test the method for estimating the defective state of ferrite ceramics. Their parameters are shown in Table 1.

Table 1. Ferrite samples parameters.

Sample	Density, g/cm^3	Porosity, %	Grain size, μm	T_c , $^\circ\text{C}$	M_s , emu/g
3CH-18, $T_s=1150\text{ C}$, $t_s=1\text{ h}$	4.29	4.5	20	277	36.1
SL-187, $T_s=960\text{ C}$, $t_s=8\text{ h}$	4.3	4.4	47	277	34.1

The phenomenological expression (2) was used to a mathematical analysis of the experimental temperature dependences.

$$\mu_i^* = \frac{1+x}{1+N \cdot x} \quad x = \left[\frac{\left(1 - \frac{T}{T_c}\right)^\delta}{\alpha \left(1 - \frac{T}{T_c}\right)^\gamma + \beta} \right]^g \quad (2)$$

In the expression (2) the coefficients α , β , γ and δ are determined by the relations: $\alpha = \frac{K_1(0)}{M_s^r(0)}$, $\beta = \frac{\lambda_s(0)}{M_s^r(0)} \cdot \sigma$, $\delta = (r \cdot n) f$, $\gamma = (m \cdot n) f$. In these relations σ is average level of elastic stresses.

With positive values of γ and δ , function (2) describes an asymmetric peak shape, distinctive for typical dependences $\mu_i(T)$.

Indicators g and r are set according to the selected magnetization mechanism. For example, for the model of rotation of magnetic moments (the case of single-domain particles) $g = 1$, $r = 2$. For the spherical bending model of 180° domain walls fixed at grain boundaries and other structural defects $g = 2$, $r = 2$ (Smith and Wijn model), for cylindrical bending of domain walls (Kersten model) $g = 0.5$, $r = 3$. The Smith and Wijn model is most frequently used for polycrystalline ferrites [11].

X-ray diffraction data confirmed the formation of well-defined homogeneous single phase cubic spinel structure for all samples. Samples have similar values of T_c and M_s , density and porosity, but the average grain size for them is significantly different. The least-squares method (the Levenberg-Marquardt algorithm) was used to process the experimental temperature dependences of initial permeability in software package Origin 9.

Table 2 shows the results of mathematical processing for the temperature dependences of initial permeability of samples sintered both in laboratory conditions at $T_s = 1150^\circ\text{C}$ for 1 h (Figure 3) and in the factory conditions at $T_s = 960^\circ\text{C}$ for 8 h (Figure 4). Also Table 2 presents the values of the maxima of the temperature dependences of initial permeability near the Curie point, μ_{max} .

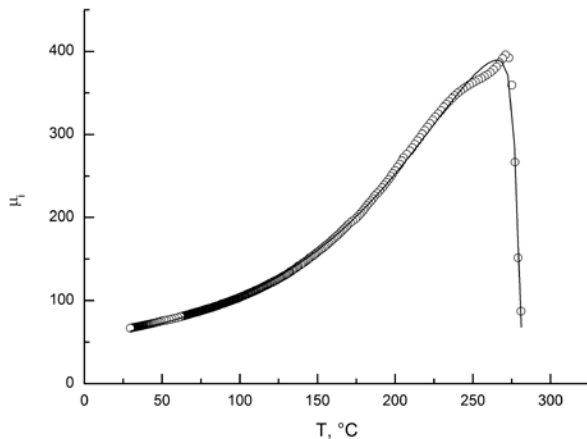

Figure 3. Temperature dependence of initial permeability for laboratory ferrite ceramics (symbols). The solid line is the calculated curve in expression 2 ($g=2$).

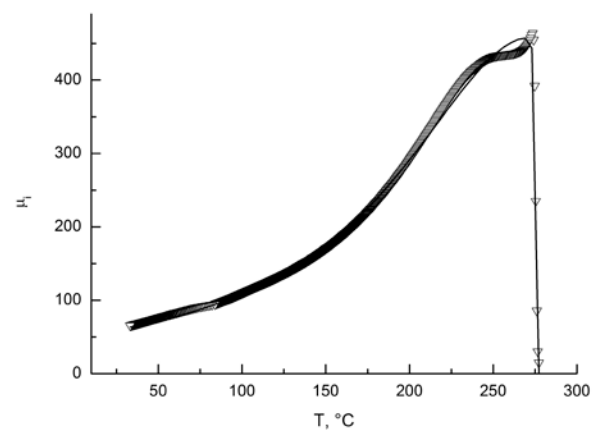

Figure 4. Temperature dependence of initial permeability for reference material SL-187.

Table 2. The fitting results.

Sintering regimes	α	β	N	$T_c, ^\circ\text{C}$	μ_{max}	β/α
$T_s=1150^\circ\text{C}$ $t=1\text{ h}$	$0.1368\pm 5.45455\text{E-}4$	1.96921E- $6\pm 1.19331\text{E-}6$	0.00275 ± 1.7708 $3\text{E-}5$	283 ± 0.28 558	395	2.3×10^{-6}
$T_s=960^\circ\text{C}$ $t=8\text{ h}$	0.13425 ± 0.0004	2.278E- $6\pm 9.0966\text{E-}7$	0.00216 ± 4.4101 $\text{E-}6$	277.2674 8 ± 0.0249	464	2×10^{-5}

Figure 3 shows the temperature dependences of initial permeability for laboratory ferrite ceramics and Figure 4 for reference material. The solid lines in these Figures are the calculated curve in expression (2). As can be seen from these Figures, the calculated curve describes rather well the experimental points, except for the Hopkinson peak.

The Hopkinson peak on the temperature dependence of initial permeability obtained for samples of both types (Figure 3 and Figure 4) reveals the effect of an increase in the initial permeability in the vicinity of the Curie point due to a sharp drop in the crystallographic magnetic anisotropy. Such behavior is due to the transition of magnetic particles (domains) to the superparamagnetic state, which is inherent in the single-domain state in the case when the domain size and the average grain size are the same, for example, in the case of nanoparticles [12–22].

It can be seen from Table 1 and Table 2 that the maximum temperature dependence of initial permeability (μ_{max}) is observed for the reference sample, in spite of the considerable

porosity. Consequently, the most perfect structure is characteristic for reference samples. Perhaps this behavior is due to the large grain size of reference samples of ferrite ceramics. Herewith a larger number of magnetic domains being formed in the bulk of the grains, compared to laboratory samples.

4. Conclusions

A method for estimating the defective state of ferrite ceramics was developed and tested on the basis of measurements of the temperature dependence of initial permeability.

It is shown that the main criterion of the defect state is the β/a parameter of the phenomenological expression associated with the elastic stresses in the material.

The result of mathematical processing showed that the level of the defective state of the sample sintered in the laboratory is lower in comparison with the reference samples. An indicator of the perfection of the structure is also the value of the maximum of the initial permeability near the Curie point.

Acknowledgements

The research is funded from The Ministry of Education and Science of the Russian Federation in part of the “Science” program.

References

- [1] Zheludev I S 1968 *Physics of Crystalline Dielectrics* (Moscow: Nauka) p 464 (in Russian)
- [2] Rankis G Zh 1981 *The dynamics of the magnetization in polycrystalline ferrites* (Riga: Zinatne) p 187 (in Russian)
- [3] Surzhikov A P et al 2013 *Russ. Phys. J.* **56** 681–685 doi:10.1007/s11182-013-0085-6
- [4] Malyshev A V et al 2016 *Ceramics International* **42** 16180–16183 doi:10.1016/j.ceramint.2016.07.137
- [5] Ghodake J S et al 2015 *J. Magn. Magn.Mater.* **378** 436–439 doi:10.1016/j.jmmm.2014.11.041
- [6] Parvin R, Momin A A, Hossain A K M 2016 *J. Magn. Magn.Mater.* **401** 760–769 doi: 10.1016/j.jmmm.2015.10.130
- [7] Lysenko E N et al 2015 *Journal of Thermal Analysis and Calorimetry* **122** 1347–1353 doi:10.1007/s10973-015-4849-9
- [8] Surzhikov A P et al 2014 *Russ. Phys. J.* **57** 621–626 doi: 10.1007/s11182-014-0284-9
- [9] Frangulyan T S et al 2006 *Russ. Phys. J.* **49** 506–510 doi: 10.1007/s11182-006-0133-6
- [10] Surzhikov A P et al 2012 *Journal of Thermal Analysis and Calorimetry* **108** 1207–1212 doi:10.1007/s10973-011-1734-z
- [11] Neel L 1963 *C. R. Acad. Sci.* **257** 2917–2932
- [12] Slama J et al 2011 *Journal of electrical engineering* **62** 239–243 doi: 10.2478/v10187-011-0038-7
- [13] Manikandan M et al 2015 *Phys. Status Solidi A* **212** 2179–2185 doi: 10.1002/pssa.201532229
- [14] Chinnasamy C N et al 2002 *J. Magn. Magn.Mater.* **238** 281–287 doi: 10.1016/S0304-8853(01)00928-3
- [15] Hoque S M et al 2011 *Materials Sciences and Applications* **2** 1564–1571 doi: 0.4236/msa.2011.211209
- [16] Hu J et al 2007 *Physica B* **400** 119–123 doi: 10.1016/j.physb.2007.06.026
- [17] Ghodake J S et al 2015 *J. Magn. Magn.Mater.* **378** 436–439 doi: 10.1016/j.jmmm.2014.11.041
- [18] Momin A A et al 2017 *J. Magn. Magn.Mater.* **423** 124–132 doi: 10.1016/j.jmmm.2016.09.078
- [19] Hoekstra B et al 1978 *Journal of Applied Physics* **49** 4902–4907 doi: 10.1063/1.325524
- [20] Alten W J et al 1967 *J. Appl. Phys.* **38** 3023–3024
- [21] Xu Z C 2003 *J. Appl. Phys.* **93** 4746–4749 doi: 10.1063/1.1562745
- [22] Slama J et al 2011 *Journal of electrical engineering* **62** 239–243 doi: 10.2478/v10187-011-0038-7