

School of Nuclear Science & Engineering

Field of training (speciality): 14.03.02 Nuclear Science and Technology

Nuclear Fuel Cycle Division

BACHELOR THESIS

| |
|---|
| Topic of the research work Mathematical model of the process of separation of ionic mixtures in an asymmetric electric field |
|---|

UDC 546-38-042.55:537.21:519.876

Student

| Group | Full name | Signature | Date |
|-------|------------------------------|-----------|------|
| 0A8D | Usoltsev Roman Alexandrovich | | |

Scientific supervisor

| Position | Full name | Academic degree, academic rank | Signature | Date |
|-----------------------------|----------------|--------------------------------|-----------|------|
| Associate professor of NFCD | Timchenko S.N. | PhD | | |

Consultant

| Position | Full name | Academic degree, academic rank | Signature | Date |
|-------------------------|--------------------|--------------------------------|-----------|------|
| Senior lecturer of NFCD | Poberezhnikov A.D. | | | |

ADVISERS:

Section «Financial Management, Resource Efficiency and Resource Saving»

| Position | Full name | Academic degree, academic rank | Signature | Date |
|---------------------|---------------|--------------------------------|-----------|------|
| Associate professor | Yakimova T.B. | PhD | | |

Section «Social Responsibility»

| Position | Full name | Academic degree, academic rank | Signature | Date |
|---------------------|----------------|--------------------------------|-----------|------|
| Associate professor | Perederin Y.V. | PhD | | |

ADMITTED TO DEFENCE:

| Programme Director | Full name | Academic degree, academic rank | Signature | Date |
|--------------------------------|--------------|--------------------------------|-----------|------|
| Nuclear Science and Technology | Bychkov P.N. | PhD | | |

LEARNING OUTCOMES

| Competencies code | Competence name |
|---|--|
| Universal competences | |
| UC(U)-1 | Ability to make critical analysis of problem-based situations using the systems analysis approach, and generate decisions and action plans. |
| UC(U)-2 | Ability to determine the range of tasks within the framework of the goal and choose the best ways to solve them, based on current legal regulations, available resources and restrictions |
| UC(U)-3 | Ability to carry out social interaction and realize their role in the team |
| UC(U)-4 | Ability to carry out business communication in oral and written forms in the state language of the Russian Federation and foreign language(s) |
| UC(U)-5 | Ability to perceive the intercultural diversity of society in the socio-historical, ethical and philosophical contexts |
| UC(U)-6 | Ability to manage his time, build and implement a trajectory of self-development based on the principles of education throughout life |
| UC(U)-7 | Ability to maintain the proper level of physical fitness to ensure full-fledged social and professional activities |
| UC(U)-8 | Ability to create and maintain safe living conditions, including in case of emergencies |
| UC(U)-9 | Ability to show entrepreneurship in professional activities, incl. as part of the development of a commercially promising product based on a scientific and technical idea |
| General professional competences | |
| GPC(U)-1 | Ability to use basic knowledge of natural sciences in professional activities, apply methods of mathematical analysis and modeling, theoretical and experimental research |
| GPC(U)-2 | Ability to search, store, process and analyze information from various sources and databases, provide it in the required format using information, computer and network technologies |
| GPC(U)-3 | Ability to use modern information systems in professional activities, analyze the dangers and threats arising from this, comply with the basic requirements of information security, including the protection of state secrets |
| Professional competences | |
| PC(U)-1 | Ability to use scientific and technical information, domestic and foreign experience on research topics, modern computer technologies and information resources in their subject area |
| PC(U)-2 | Ability to carry out mathematical modeling of processes and objects of the nuclear industry using standard methods and computer codes for design and analysis |
| PC(U)-3 | Ready for conducting physical experiments according to a given methodology, compiling a description of ongoing research and analyzing the experimental data obtained |
| PC(U)-4 | Ability to use technical means to measure the main parameters of research objects |
| PC(U)-5 | Ready to draw up a report on the completed task, to participate in the implementation of research and development results |
| PC(U)-6 | Ability to use information technologies in the development of new installations, materials and devices, to the collection and analysis of initial data for the design of nuclear industry facilities |
| PC(U)-7 | Ability to calculate and design parts and assemblies of devices and installations in accordance with the terms of reference |
| PC(U)-8 | Ready for the development of design and working technical documentation, registration of completed design work |
| PC(U)-9 | Способен к контролю соответствия разрабатываемых проектов и технической документации стандартам, техническим условиям, требованиям безопасности и другим нормативным документам |
| PC(U)-10 | Ready to conduct a preliminary feasibility study of design solutions in the development of installations and devices |
| PC(U)-11 | Capable of monitoring the observance of technological discipline and maintenance of technological equipment |
| PC(U)-12 | Ready for operation of modern physical equipment, instruments and technologies |
| PC(U)-13 | Ability to assess nuclear and radiation safety, to assess the impact on the environment, to monitor compliance with environmental safety, safety regulations, norms and rules of industrial sanitation, fire, radiation and nuclear safety, labor protection standards |
| PC(U)-14 | Ready to develop ways to use nuclear power, plasma, laser, microwave and high-power pulse installations, electron, neutron and proton beams, methods of experimental physics in solving technical, technological and medical problems |
| PC(U)-15 | Ability to draw up technical documentation (work schedules, instructions, plans, estimates, applications for materials, equipment), as well as established reporting in approved forms |

| | |
|--|--|
| List of the issues to be investigated, designed and developed | Development of a program in the software package for modeling the concentration field in the separation cell of the experimental setup. The results of modeling the concentration field from the value of the input parameters. |
| List of graphic material | <ul style="list-style-type: none"> – Presentation – Experimental setup geometry – Simulation results |

Advisors to the sections of the Bachelor Thesis

(with indications of sections)

| Section | Advisor |
|---|--------------------|
| Literature review; Analytical solution of the equation; Numerical solution of the equation; Parameter analysis; Results of modeling the concentration field in the separation cell. | Poberezhnikov A.D. |
| Financial Management, Resource Efficiency and Resource Saving | Yakimova T.B. |
| Social Responsibility | Perederin Y.V. |

Date of issuance of the assignment for Bachelor Thesis completion according to the schedule

01.02.2022

Assignment issued by a scientific supervisor / advisor:

| Position | Full name | Academic degree, academic rank | Signature | Date |
|--------------------------------|--------------------|-----------------------------------|-----------|------|
| Associate professor of NFCD | Timchenko S.N. | PhD | | |
| Senior lecturer of NFCD | Poberezhnikov A.D. | | | |

Assignment accepted for execution by a student:

| Group | Full name | Signature | Date |
|-------|------------------------------|-----------|------|
| 0A8D | Usoltsev Roman Alexandrovich | | |

**ASSIGNMENT FOR SECTION
«FINANCIAL MANAGEMENT, RESOURCE EFFICIENCY AND RESOURCE
SAVING»**

Student:

| Group | Full name |
|-------|------------------------------|
| 0A8D | Usoltsev Roman Alexandrovich |

| | | | |
|---------------|---------------------------------|--------------------------|----------------------------------|
| School | Nuclear Science and Engineering | Division | Nuclear Fuel Cycle |
| Degree | Bachelor | Field of training | Nuclear physics and technologies |

Initial data to the section «Financial management, resource efficiency and resource saving»:

| | |
|--|--|
| 1. <i>The cost of scientific research resources (SR): logistical, energy, financial, informational and human</i> | <i>The cost of material resources in accordance with the market prices of the city of Tomsk. Tariff rates of performers in accordance with the staffing table of NR TPU.</i> |
| 2. <i>Norms and standards of resource spending</i> | <i>Coefficients for payroll calculation.</i> |
| 3. <i>Taxation system used, tax rates, deductions, discounting and lending</i> | <i>The coefficient of deductions to off-budget funds is 30.2 %.</i> |

The list of subjects to study, design and develop:

| | |
|--|---|
| 1. <i>Evaluation of the commercial potential, prospects and alternatives for conducting scientific research from the standpoint of resource efficiency and resource saving</i> | <i>Analysis of potential consumers of the research results. Research of competitive technical solutions. Conducting a SWOT analysis</i> |
| 2. <i>Planning and budgeting for scientific research</i> | <i>Determination of labor intensity of work. Development of a schedule for conducting a scientific study. Formation of the budget for the costs of a research project</i> |
| 3. <i>Determination of resource (resource-saving), financial, budgetary, social and economic efficiency of the study</i> | <i>Conducting an assessment of the comparative effectiveness of the project.</i> |

A list of a graphic material:

1. *Assessment of the competitiveness of technical solutions*
2. *SWOT matrix*
3. *Schedule and budget for NI*
4. *Assessment of resource, financial and economic efficiency of research*

| | |
|--|------------|
| Date of issue of the task for the section according to the schedule | 15.03.2022 |
|--|------------|

Assignment issued by an advisor:

| Position | Full name | Academic degree, academic rank | Signature | Date |
|---------------------|---------------|--------------------------------|-----------|------------|
| Associate professor | Yakimova T.B. | PhD | | 15.03.2022 |

Assignment accepted for execution by a student:

| Group | Full name | Signature | Date |
|-------|---------------|-----------|------------|
| 0A8D | Usoltsev R.A. | | 15.03.2022 |

**ASSIGNMENT FOR SECTION
«SOCIAL RESPONSIBILITY»**

Student:

| | |
|--------------|------------------------------|
| Group | Full name |
| 0A8D | Usoltsev Roman Alexandrovich |

| | | | |
|---------------|---------------------------------|--------------------------|----------------------------------|
| School | Nuclear Science and Engineering | Division | Nuclear Fuel Cycle |
| Degree | Bachelor | Field of training | Nuclear physics and technologies |

Topic of the research work:

| | |
|--|---|
| Mathematical model of the process of separation of ionic mixtures in an asymmetric electric field | |
| Initial data to the section «Social responsibility»: | |
| 1. Characteristics of the object of study (substance, material, device, algorithm, technique, working area) and areas of its application | Object of study: gamma-ray unit ROKUS-AMT Scope: nuclear industry. |
| List of issues to be researched, designed and developed: | |
| 1. Legal and organizational issues of security: – special (characteristic for the operation of the object of study, the designed working area) legal norms of labor legislation; – organizational measures in the layout of the working area. | – Legal norms of labor legislation; – Requirements for the organization and equipment of workplaces with a PC: – GOST 22269-76. The «man-machine» system. Operator's workplace. Mutual arrangement of elements of the workplace. General ergonomic requirements. |
| 2. Industrial safety: 2.1. Analysis of identified harmful and dangerous factors 2.2. Rationale for mitigation measures | Harmful and dangerous factors: – deviation of microclimate indicators; – increased level of electromagnetic radiation; – insufficient illumination of the working area; – increased noise level; – psychophysiological factors; – risk of electric shock. |
| 3. Environmental safety: | – analysis of the impact of the object and the research process on the environment; – development of organizational and technical measures to protect the environment. |
| 4. Safety in emergency situations: | – selection and description of a typical emergency situation: fire; – substantiation of measures to prevent emergencies; – procedure for action in the event of an emergency. |

| | |
|--|------------|
| Date of issue of the task for the section according to the schedule | 15.03.2022 |
|--|------------|

Assignment issued by an advisor:

| | | | | |
|---------------------|------------------|---------------------------------------|------------------|---------------|
| Position | Full name | Academic degree, academic rank | Signature | Date |
| Associate professor | Perederin Y.V. | PhD | | 15.03.2022 y. |

Assignment accepted for execution by a student:

| | | | |
|--------------|------------------|------------------|---------------|
| Group | Full name | Signature | Date |
| 0A8D | Usoltsev R.A. | | 15.03.2022 y. |

Министерство науки и высшего образования Российской Федерации
 федеральное государственное автономное
 образовательное учреждение высшего образования
 «Национальный исследовательский Томский политехнический университет» (ТПУ)

School of Nuclear Science & Engineering

Field of training (speciality): 14.03.02 Nuclear Science and Technology

Nuclear Fuel Cycle Division

Period of completion _____ (spring semester 2021/2022 academic year)

Form of presenting the work:

| |
|-----------------|
| Bachelor Thesis |
|-----------------|

SCHEDULED ASSESSMENT CALENDAR for the Bachelor Thesis completion

| | |
|---|------------|
| Deadline for completion of Bachelor Thesis: | 31.05.2022 |
|---|------------|

| Assessment date | Title of section (module) / type of work (research) | Maximum score for the section (module) |
|-------------------|--|--|
| <i>05.02.2022</i> | <i>Setting goals and objectives</i> | <i>5</i> |
| <i>07.02.2022</i> | <i>Drafting and approval of TT</i> | <i>5</i> |
| <i>30.02.2022</i> | <i>Selection and study of materials on the subject</i> | <i>10</i> |
| <i>01.03.2022</i> | <i>Development of the calendar plan</i> | <i>5</i> |
| <i>06.03.2022</i> | <i>Literature discussion</i> | <i>10</i> |
| <i>12.04.2022</i> | <i>Program development</i> | <i>15</i> |
| <i>17.04.2022</i> | <i>Spectra study</i> | <i>10</i> |
| <i>24.05.2022</i> | <i>Program verification</i> | <i>20</i> |
| <i>31.05.2022</i> | <i>Registration of a settlement and explanatory note</i> | <i>20</i> |

COMPILED BY:

Scientific supervisor:

| Должность | Full name | Academic degree, academic rank | Signature | Date |
|-----------------------------|----------------|--------------------------------|-----------|------|
| Associate professor of NFCD | Timchenko S.N. | PhD | | |

APPROVED BY:

Program Director

| Position | Full name | Academic degree, academic rank | Signature | Date |
|---------------------|--------------|--------------------------------|-----------|------|
| Associate professor | Bychkov P.N. | PhD | | |

ABSTRACT

Thesis: 91 pages, 15 figures, 31 tables, 33 used sources, 1 applications.

Keywords: Model, Selective, Drift, Monte Carlo, Programming.

The object of research is an experimental setup for isotope separation.

The subject of research is the field of ion concentration in the separation cell of the installation.

Purpose of work: to develop a mathematical model of the process of electrically induced selective drift of ions in aqueous solutions of their electrolytes, used in the reagentless separation of alkaline earth elements.

In the course of the study, a program was developed and verification was carried out according to known experimental data: the distribution of the ion concentration over the volume of the separating cell of the installation. The concentration fields are obtained for various initial parameters.

A mathematical description of the processes occurring in the separating cell under the action of the field has been developed. The model is a differential equation in a series of 2nd order derivatives with boundary situations.

An analytical and numerical solution of the differential equation is performed. The smallest discrepancy between the numerical and estimated bases is 9%, the standard deviation of the numerical solution is 0.006.

Certain parameters influencing the selection process are the solution flow rate and the electromigration rate. The main contribution to the change in concentration is made by the rate of electromigration.

This model can be used in the future for planning experiments using complex fields.

CONTENTS

| | |
|---|----|
| INTRODUCTION..... | 11 |
| 1. LITERATURE REVIEW | 12 |
| 1.1 Nuclear fuel cycle..... | 12 |
| 1.2 Nuclear fuel cycle solvent extraction | 13 |
| 1.3 Principles of Li^+ migration and isotope separation with different driving forces. | 15 |
| 1.4 Effect of diffusion on Li isotope separation. migration of Li^+ and driving forces..... | 17 |
| 1.5 Enrichment of lithium isotopes. | 18 |
| 1.6 Effect of an electric field on the ions of aquacomplexes | 20 |
| 1.7 Installation description | 22 |
| 1.8 Statistical processing | 24 |
| 2. PRACTICAL PART | 26 |
| 2.1 Analytical solution..... | 26 |
| 2.2 Solution analysis..... | 36 |
| 2.3 Numerical solution | 39 |
| 2.4 Program description..... | 40 |
| 2.5 Simulation results of the concentration field in a separator cell | 42 |
| 2.6 Model verification | 46 |
| 3. FINANCIAL MANAGEMENT, RESOURCE EFFICIENCY AND RESOURCE SAVING..... | 49 |
| 3.1. Potential consumers graduation qualification thesis | 49 |
| 3.2. Analysis of competitive technical solutions..... | 50 |
| 3.3. SWOT-analysis..... | 51 |
| 3.4. Project Planning..... | 54 |
| 3.4.1. Determination of the complexity of performing graduation qualification thesis..... | 55 |
| 3.4.2 Development of a schedule for graduation qualification thesis | 56 |
| 3.5. Project's budget..... | 60 |
| 3.5.1. Material costs | 60 |
| 3.5.2. Special Equipment Costs..... | 61 |
| 3.5.3. Salary of graduation qualification thesis performers..... | 61 |
| 3.5.4. Deductions to off-budget funds..... | 63 |
| 3.5.5. Overheads..... | 63 |
| 3.5.5. Formation of the cost budget graduation qualification thesis | 64 |
| 3.6. Determination of resource (resource-saving) efficiency graduation qualification thesis..... | 64 |

| | | |
|--------|--|----|
| 3.6.1. | Evaluation of the scientific and technical effect | 64 |
| 3.6.2. | Evaluation of the comparative effectiveness of the study | 67 |
| | Section Conclusions | 68 |
| 4. | SOCIAL RESPONSIBILITY | 69 |
| 4.1 | Legal and organizational issues of security..... | 69 |
| 4.1.1. | Special (characteristic for the researcher's working area) legal norms of labor legislation..... | 69 |
| 4.1.2. | Special (characteristic for the researcher's working area) legal norms of labor legislation..... | 70 |
| 4.2 | Legal and organizational issues of security..... | 72 |
| 4.2.1. | Analysis of harmful and dangerous factors..... | 72 |
| 4.3 | Justification of measures to protect the researcher from the action of harmful and dangerous factors | 73 |
| 4.3.1. | Deviation of microclimate indicators..... | 73 |
| 4.3.2. | Increased level of electromagnetic radiation..... | 74 |
| 4.3.3. | Insufficient illumination of the working area | 75 |
| 4.3.4. | Exceeding the noise level..... | 78 |
| 4.3.5. | Psychophysiological factors..... | 79 |
| 4.3.6. | Electrical safety | 80 |
| 4.4 | Environmental safety..... | 81 |
| 4.5 | Fire and explosion safety..... | 82 |
| 4.6 | Emergency Safety..... | 84 |
| 4.6.1. | Analysis of typical emergencies during the study | 84 |
| | Section Conclusions | 85 |
| | MAIN RESULTS AND CONCLUSIONS | 87 |
| | LIST OF USED SOURCES..... | 88 |
| | SUPPLEMENT A | 91 |

INTRODUCTION

At present, the research of new, economical methods of isotope separation, which are used in various industries, is topical. Separation methods are used to obtain highly pure substances, as well as to process various types of waste. In this case, reagent-free separation methods are especially important, which greatly reduce production costs and increase environmental safety.

One of such methods is selective electrically induced drift. A distinctive feature of which is the isolation of the solution from the electrodes, which can be useful when working with aggressive media. However, the theoretical description of this method of separation and experimental study in the global practice is clearly insufficient.

1. LITERATURE REVIEW

1.1 Nuclear fuel cycle

At the atomic level, all elements are reusable, i.e. they can be recycled indefinitely. Recycling desirable elements from compounds requires chemically dissolving compounds in a medium, such as acids, then separating them into their constituents. However, as there is ever-growing global demand and a comprehensive understanding that resources are finite, closed-cycle systems for the scarce and endangered elements must be implemented to avoid losing them. This drives the pursuit to supersede the open cycle and develop a circular economy,¹ where waste is eliminated, materials are recycled and recirculated, and both resources and the environment are protected. In the nuclear sector, separation of elements from irradiated fuel has always been fundamental. However, with the initial purpose of recovering plutonium for nuclear weapons, but concurrently the civil nuclear industry has driven the development of recycle technology, creating a circular economy for the sustainable use of f-block elements for civilian power generation.²

At present, most nuclear nations pursue an unsustainable open cycle, where the disposal of spent nuclear fuel without separation in deep geological disposal facilities is the norm.³ If this situation continues, current estimates of virgin uranium sources are estimated to last 80 years.³ The consumption, or ‘burning,’ of virgin nuclear fuel is the conversion of fissile isotopes into fission products, neutrons and electromagnetic radiation, occurring at the atomic level traditionally in pure uranium oxide pellets. Fuel is defined as “spent,” (or more appropriately as “used”), once a portion of the fissile isotopes are consumed, resulting in the build-up of fission products, impeding further fission reactions and energy generation. Chemically, spent nuclear fuel does not differ significantly from virgin fuel, as only a small proportion of the uranium is converted (equating to the fissile content), so the composition of spent fuel (typically) consists of 96% the original uranium, with the 4% consisting of mixed fissile and fertile higher actinides, lanthanides and fission products. The chemical composition will further vary

after every successful open cycle burnup as heavier transuranics become more prevalent.

Recycling these materials provides access to a closed fuel cycle which has many advantages.^{4,5} One advantage will be a reduction in the size of Geological Disposal Facilities (GDFs), as a result of reduced decay time, reduced heat loadings to the GDFs, reduced radiotoxicity and reduced size through consumption of fertile material whilst maintaining fissile content in fourth-generation fast reactors.³ Numerous commercial-scale facilities have been built worldwide to recycle spent nuclear fuel, primarily based on the Plutonium Uranium Reduction EXtraction (PUREX) process that uses solvent extraction to separate U and Pu from unwanted fission products.⁶ Future developments have looked to extend the range of species recovered to include Np, Am, and Cm to increase the fuel cycle's sustainability. Furthermore, 'bolt-on' flowsheets have been designed to treat the PUREX raffinate/waste generated to further reduce the decay time and heat loading, for example, using the Selective ActiNide EXtraction (SANEX) process to extract An³⁺.³ As these new processes are developing, there is a parallel development of solvent extraction technology to intensify the process and drive down costs. A series of partitioning approaches have been demonstrated in centrifugal contactors (CC) to intensify the process.⁷

The wide range of elements present in spent nuclear fuel and the flowsheet chemistry can result in unexpected side products. Furthermore, implementing these chemical reactions at different scales and intensities can further deviate from the expected behaviour. Of particular concern is the presence of solids, either formed in situ or entrained, as these tend to adhere to CC walls due to centrifugal force, resulting in reduced extraction efficiency.

1.2 Nuclear fuel cycle solvent extraction

This part will discuss the different organic ligands demonstrated in solvent extract in CCs in the partitioning and separation of elements that simultaneously arise due to virgin nuclear fuel elements fissioning. A single aqueous solution containing a mixture of elements is typically contacted with one or more organic ligands, often in

subsequent stages, to recover specific elements selectively. Different organic ligands bind to different metal ions to form an organic soluble, metalcontaining coordination complex. This is generally achieved by electron donation from heteroatoms on the ligands to the positively charged metal ions. The majority of ligands considered in the nuclear fuel cycle are either; oxygen-only ligands or nitrogenonly ligands.⁵

Organic ligands are required to demonstrate a high selectivity towards a solute, which is reported as distribution ratios. The distribution ratio, also known as the partition ratio or simply KD, is the ratio of solute concentrations distributed between the solvent and aqueous phases after contacting them together; the higher the distribution ratio, the greater the extraction.³⁴ Performing sequential extraction also increases the chemical extraction of a solute. This can be achieved in discrete stages, such as separatory funnels. Linking together several continuous solvent extraction equipments, such as CCs, in which the two-phase are fed counter current to each other also achieve this effect, and an overall stage efficiency of a cascade of CCs can then be determined.

Ligand and solvent recycling is also desirable. This is achieved through reverse stripping, which back extracts the solutes into an aqueous phase. After solvent extraction has been performed, the ligand and solvent are defined in the literature as ‘spent solvent.’ This is due to the likelihood of radiolytic breakdown of the solvent, also known as radiolysis. Ligands used in solvent extraction of radioactive ‘hot’ elements also require additional parameters to be considered.

The earliest recycling separations that were implemented singly focused on the partitioning of uranium and plutonium from fission products in SNF. These historical methods were: Bismuth phosphate process (Hanford, USA, 1943), REDOX (Hanford, USA, 1952) and BUTEX (Windscale, UK, 1958). These processes were not performed in CCs. In this report, waste streams containing lanthanides, actinides and fission products are referred to as dissolved spent nuclear fuel, model fission product composition, PUREX raffinate, high-level waste (HLW), highly active raffinate

(HAR), sodium bearing waste (SBW), discrete aqueous feed composition devoid of fission products associated with spent nuclear fuel, and simulated tank waste.

The solvent extraction chemistries in flowsheets for different chemical compositions found in the Nuclear Fuel Cycle subsequently have been developed and implemented in CCs vary in chemistry, partitioning and aqueous feed material. The flowsheets are listed below alongside their commonly used abbreviations:

- Plutonium Uranium Reduction EXtraction (PUREX).
- Advanced PUREX. URanium EXtraction (UREX).
- Next Extraction system for Transuranium Recovery (NEXT).
- TRansUranium EXtraction (TRUEX).
- DIAMide EXtraction (DIAMEX).
- Selective ActiNide EXtraction (SANEX).
- UNiversal Extraction (UNEX).
- StRontium EXtraction (SREX).
- Trialkyl phosphine oxides/phosphine oxide (POR).
- Tri-alkylPhosphineOxide (TRPO).
- Lanthaniden und Curium Americium (LUCA).
- Caustic-Side Solvent Extraction (CSSX).
- CaeSium EXtraction (CSEX).
- Crown Ether Strontium Extraction(CESE).

The subsequent sections evaluate each flowsheet system that has been performed to elucidate successes, often greater than 99% extraction efficiencies,³⁵ and the in situ solids formed, in the presence of different solvent extraction agents and concentrations.

1.3 Principles of Li^+ migration and isotope separation with different driving forces.

The effect of three driving forces (diffusion, electromigration, and chelation) on Li^+ migration and isotope separation were investigated, while convection was ignored. The direction of Li^+ migration and ^6Li enrichment in all of the experiments with

different driving forces is shown in Figure 1. In fact, lithium ions were not in the form of naked ions but in a variety of chemical speciation in the system. For ease of description, all of the chemical speciation is denoted as Li^+ .

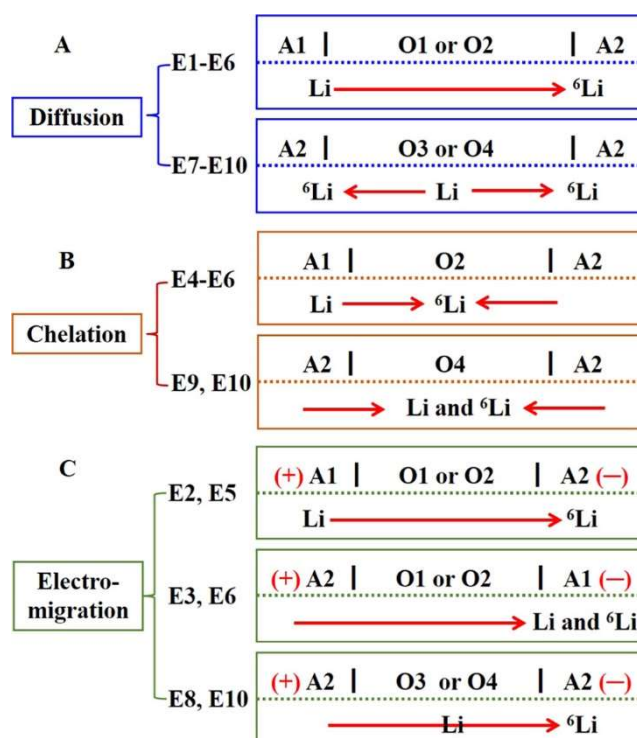

Figure 1. Direction of Li^+ migration and ^6Li enrichment with different driving forces. The parts with the “ Li ” symbol below correspond to the place where Li^+ was placed at the beginning. The “ \rightarrow ” symbol corresponds to the migration direction of Li^+ and the parts with the “ ^6Li ” symbol below correspond to the part where ^6Li should be enriched under a single driving force.

Where it needs to be clearly explained, specific chemical speciation is given. Diffusion existed in all of the experiments, in which Li^+ migrated from the high-concentration part (A1 or O3 or O4) to the low-concentration part (A2). The diffusion was just driven by the Li^+ concentration gradient. The direction of Li^+ diffusion migration was independent of the electric field and chelation. If diffusion was considered alone, the direction of ^6Li enrichment was always consistent with the direction of Li^+ greater the Li^+ concentration difference, the stronger the diffusion and the more significant the isotope separation effect.

Chelation existed in the system with crown ether, in which Li^+ migrated to the parts (O2 or O4) where crown ether stayed. The chelation migration was driven by

selective coordination of crown ether to Li^+ . If chelation was considered alone, the direction of ^6Li enrichment always pointed to the organic solution (O2 or O4) because $^6\text{Li}^+$ can match crown ether better than $^7\text{Li}^+$. When the crown ether concentration remained unchanged, the more the Li^+ concentration in the organic solution neared the saturation capacity, the weaker its ability of chelation and isotope separation became, and vice versa.

Electromigration existed in the system under the electric field. The direction of Li^+ electromigration was from the anode to the cathode no matter at which part Li^+ was placed. The electromigration was driven by selective guidance of the direct current field on Li^+ . If electromigration was considered alone, the direction of ^6Li enrichment always pointed to the cathode because $^6\text{Li}^+$ ran faster than $^7\text{Li}^+$. If the state of solution, Li^+ , and voltage remained unchanged, the electromigration force of Li^+ in the system remained unchanged.

The direction and strength of a single force were easy to judge according to common sense, but when multiple forces coexisted, their mutual influence on the migration of Li^+ and the enrichment of isotopes needed to be determined by experiments. The seemingly abnormal results can be reasonably explained only by the synergistic effect of multiple forces.

1.4 Effect of diffusion on li isotope separation. migration of li+ and driving forces.

For E1, Li^+ migrated from the Li salts solution (A1) into the NH_4Cl aqueous solution (A2) via the ionic liquid–anisole organic solution (O1). For E7, Li^+ diffused from the ionic liquid–anisole organic solution loaded with Li^+ (O3) into the NH_4Cl aqueous solution (A2) on both sides. The only driving force of Li^+ migration for both E1 and E7 was diffusion based on the Li^+ concentration difference among different parts of the system. The migration direction of Li^+ with different driving forces is shown in Figure 1. According to Table 2, the Li^+ concentration ratio of NH_4Cl aqueous solution (A2) to Li salts solution (A1), ionic liquid–anisole organic solution (O1) to Li salts solution (A1), and NH_4Cl aqueous solution (A2) to ionic liquid–anisole organic

solution (O1) of E1 and that of both NH₄Cl aqueous solutions (A2) to ionic liquid–anisole organic solution loaded with the Li⁺ (O3) of E7 was 0.06, 0.03, 191.67, 16, and 12%, respectively.

Table 2. Concentration, $\delta^7\text{Li}$, and $\Delta^7\text{Li}$ of Li⁺ of E1 and E7

| number | samples after processing | concentration of Li ⁺ (mg/L) | $\delta^7\text{Li}$ | $\Delta^7\text{Li}$ |
|--------|--------------------------|---|---------------------|---------------------|
| E1 | A1 | 720.8 | 12.7 | 2.3 |
| | O1 | 0.24 | | |
| | A2 | 0.46 | 3.8 | -6.6 |
| E7 | A2 | 0.08 | 3.4 | -7.0 |
| | O3 | 0.50 | | |
| | A2 | 0.06 | 4.2 | -6.2 |

The concentration ratio represented the migration ratio and the migration ability of Li⁺ in the different parts. The Li⁺ concentration ratio of NH₄Cl aqueous solution (A2) to Li salts solution (A1) in E1 was 0.06%, which indicated that the migration capability of Li⁺ into aqueous solution through the organic solution was low under the drive of diffusion. The Li⁺ concentration ratio of A2 to O1 in E1 was 191.67%. It indicated that the organic solution (O1) has very weak ability to retain Li⁺. So, the concentration of Li⁺ in the organic solution (O1) was lower than that in the aqueous solution (A2). In E7, the concentration ratio of both NH₄Cl aqueous solutions (A2) to the ionic liquid–anisole organic solution loaded with Li⁺ (O3) was 16 and 12%, respectively. It indicated that the Li⁺ concentration ratio of the cathode solution to the organic solution varied considerably when Li⁺ was loaded in the organic solutions by extraction vs that by electromigration.

1.5 Enrichment of lithium isotopes.

According to Figure 1A and Table 2, for E1 and E7, it was found that the parts of ⁶Li enrichment were consistent with the direction of Li⁺ diffusion, which could be attributed to the difference of diffusion rates of the lithium isotope ions. The migration rate of ⁶Li is greater than that of ⁷Li under the same diffusion conditions because ⁷Li

is heavier than ${}^6\text{Li}$ by the mass of one neutron. For the NH_4Cl aqueous solutions (A2) of E1 and E7, $\Delta^7\text{Li}$ was -6.6 , -7.0 , and -6.2 , respectively, which was similar though the migration process of Li^+ for E1 and E7 was different. The possible reason was that when Li^+ diffused from the aqueous solution into the organic solution, the process was similar to extraction, with little separation effect, but when Li^+ diffused from the organic solution into the aqueous solution, lithium isotope separation occurred. The process of Li^+ migration from the ionic liquid–anisole organic solution (O1) to NH_4Cl aqueous solution (A2) for E1 and from the ionic liquid–anisole organic solution loaded with Li^+ (O3) to NH_4Cl aqueous solution (A2) was similar, which made the $\Delta^7\text{Li}$ of NH_4Cl aqueous solutions (A2) of both E1 and E7 similar too. Though the lithium isotope separation effect was observed from E1 and E7, the concentration ratio of Li^+ for the NH_4Cl aqueous solution (A2) to the Li salts solution (A1) was just 0.06%, and the corresponding $\Delta^7\text{Li}$ was about -6.6 . So, it is necessary to find a more efficient separation routine.

1.6 Effect of an electric field on the ions of aquacomplexes

High frequency electric fields can be used to select atoms and molecules[1]. In this case, an electric field is applied to a closed volume, one of the walls of which is made of a membrane with a given surface density and pore diameter. The polarization of molecules in the volume causes the formation of a polarization charge. The action of the field on it excites the oscillatory motion of molecules and their collisions with the surface of the membrane. The difference in the diameters of isotopically different molecules ensures the penetration through the membrane of only those of them, the diameter of which is smaller than the diameter of the pores [6]. The effect of an asymmetric field on membraneless systems has not yet been considered.

In experiments on the effect of a high-frequency electric field on aqueous solutions of salts of rare earth and alkali metals, a stable effect was found, which consisted of the following. When the sinusoidal form of the dependence of the potential on the grid electrode isolated from the solution was distorted, it was found that with a decrease (increase) in the amplitude of one of the half-cycles relative to the other, a change in the pH of the solution was observed at two control points: at the grounded electrode and at the potential grid. For simplicity of presentation, a periodic sinusoidal electric potential, in which the absolute values of the amplitudes of half-periods are equal (Figure 2), will be called symmetrical. If the absolute values of the amplitudes of the half-periods differ - asymmetric. The electric field between the potential and grounded electrodes (isolated from the solution) will be called symmetric and asymmetric, respectively. If a symmetrical high-frequency electric field acted on a sodium chloride solution (physiological solution): $\nu=10\text{...}30$ kHz, $E=2\text{...}20$ V/cm, then the samples did not stain with phenolphthalein [7].

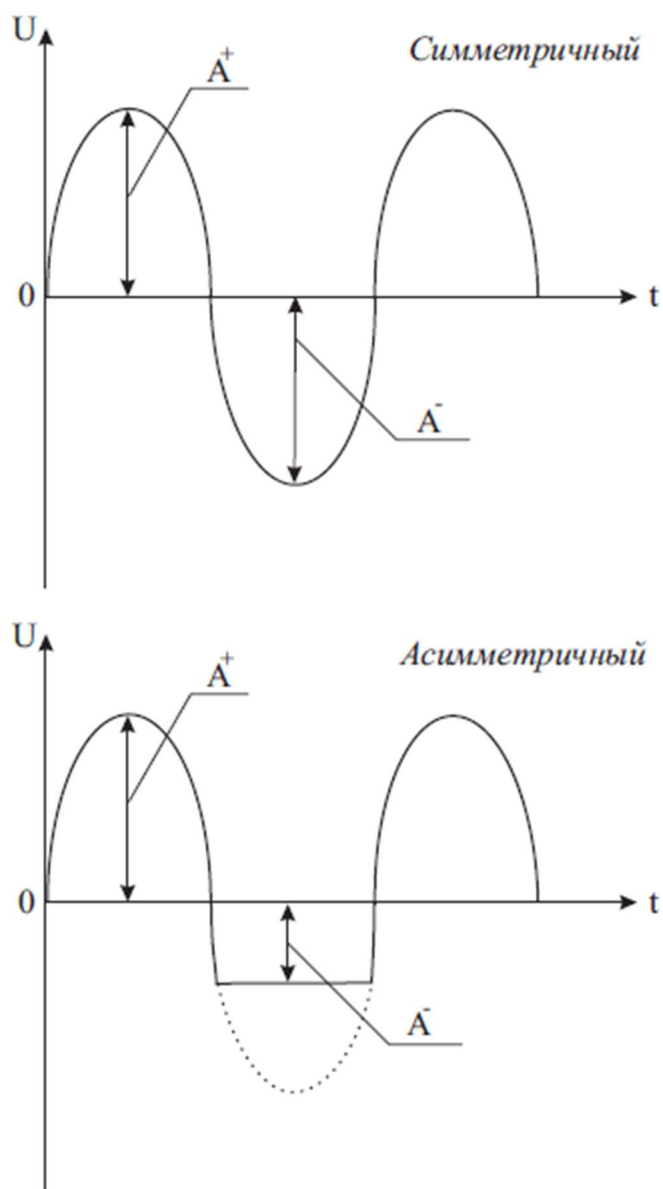

Figure 2. Dependence of the electrical potential of the grid on time: A^+ and A^- are the amplitudes of the positive and negative half-cycles, respectively.

When the field was distorted, the sample at the potential electrode stained phenolphthalein in crimson red (alkaline medium). The pH value in the sample was about 9. After the generator was turned off, this property of the solution persisted for several more hours [8].

Thus, the action of an asymmetric high-frequency electric field on a salt solution caused the drift of cationic aqua complexes. There was a need for a theoretical explanation of this effect, which, as it turned out later, is not the only one. In addition to the selective drift of cationic and anionic aquacomplexes, when an asymmetric high-

frequency electric field is applied to aqueous salt solutions, a selective drift of isotopically different both cationic and anionic aquacomplexes is excited [14]. If there is no isotopic difference, then the cationic and anionic aqua complexes simply drift in opposite directions. In the case of an isotopic difference, the drift of aquacomplexes in one direction occurs at different rates [9].

1.7 Installation description

The block diagram of the experimental complex is shown in Figure 3. The main power source of the variable frequency signal is the GZ-109 1 audio signal generator, the signal from which is fed to the input of the RUB2250 2 pre-amplifier with its own NES-100-12 3 power supply.

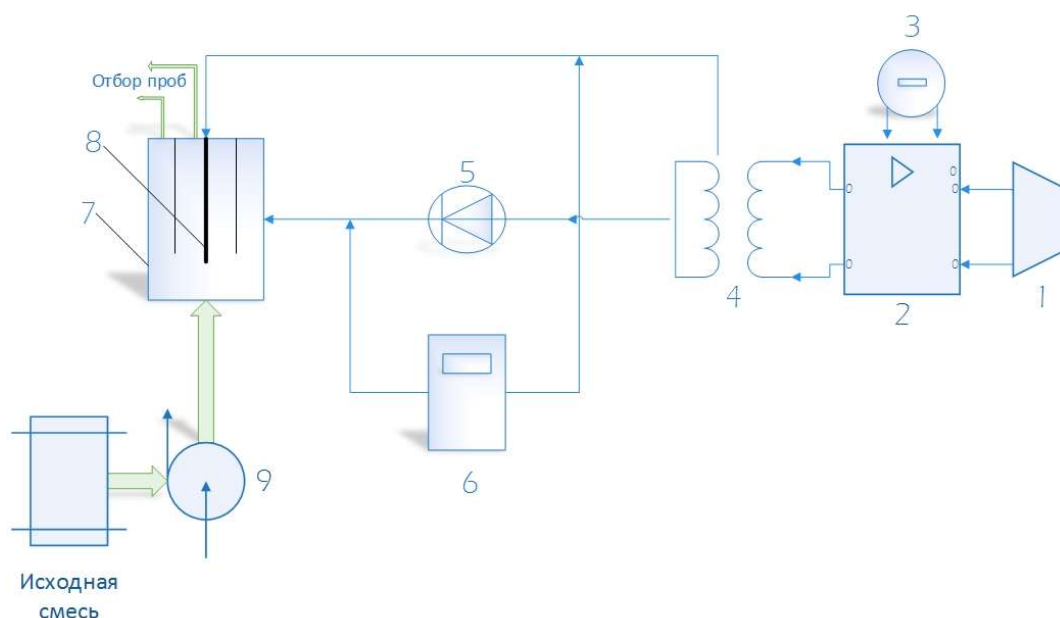

Figure 3. Block diagram of the experimental complex.

Then, the potential amplified by the transformer 4 is fed through the asymmetric signal conditioning device 5 to the central electrode 8 of the experimental device 7. In this case, the second electrode is grounded. The signal is recorded using an oscilloscope 6. During the experiments, the working solution from the container is supplied by a peristaltic pump 9 to the lower part of the experimental device. In such experiments, dilute mixtures of solutions of calcium and magnesium chlorides of chemically pure

grade were used. A general view of the experimental device, which is a cylinder, inside which the main structural elements are coaxially located, is shown in Figure 4.

In the center is a potential electrode 1 made of a steel bar, hermetically isolated from the working solution by a PVC tube. A grounded cylindrical steel electrode is hermetically sealed from the working solution with a polyethylene film. The entire volume of the working solution supplied to the lower part of the installation is divided by a polyethylene perforated cylinder 5 into the inner and outer zones. This cylinder acts as a separator between the zones of enrichment and depletion of the solution with target ions.

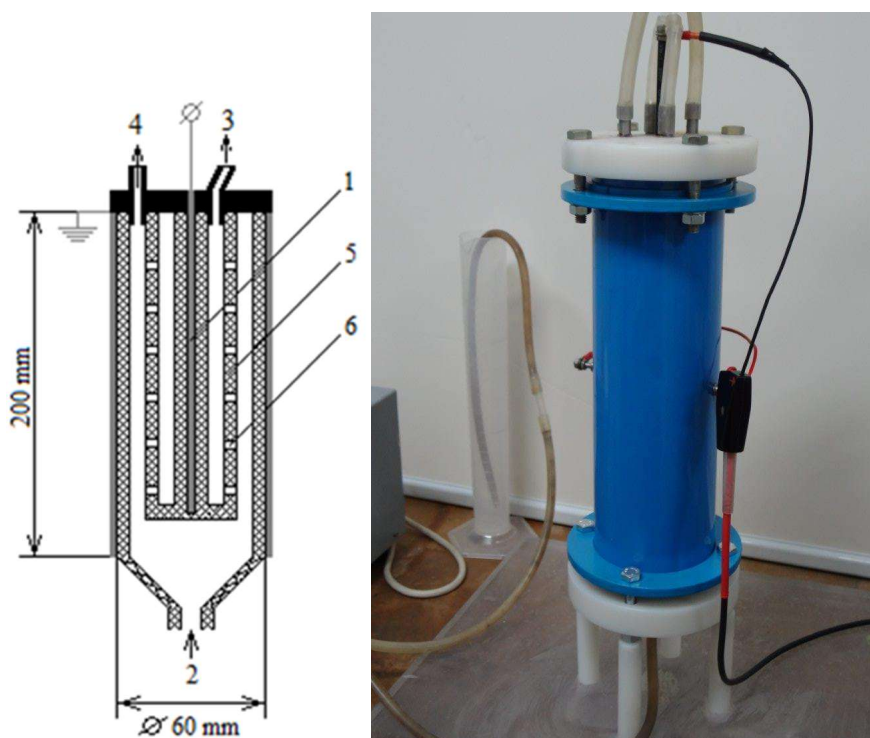

Figure 4. Photograph and schematic representation of the pilot plant in the frontal section.

The perforation of the cylinder 6 is made in the form of elongated vertical holes located azimuthally symmetrically along the generatrices of the cylinder over its entire surface. The holes allow the ionic components of the working solution to move from one zone to another. The test solution supplied through fitting 2 to the lower part of the setup moved up through both zones at the same linear velocity. The outlet of the solution in the upper part of the installation from each zone was carried out autonomously through fittings 3 and 4 and outlet hoses equipped with special screw clamps. With the help of

these clamps, the output volumes of the solution in the inner and outer zones were regulated. The velocity of the solution in the inner zone was 4-7% higher than the velocity of the solution in the outer zone. In all experiments, the nature of the movement of solutions corresponded to the laminar regime of fluid flow, and the linear velocity of the solution was no more than 4 cm/min.

During the experiments, samples of solutions were taken at certain intervals, flowing from both the inner and outer zones of the treated solution. The analysis of samples for the content of magnesium and calcium ions was carried out on an atomic emission spectrometer with inductive coupled plasma iCAP 6300 Duo.

1.8 Statistical processing

The results of statistical processing of the experimental data showed that the measurement error in all experiments did not exceed 0.014 in relative fractions of the average values. It should be noted that with the help of device 5 (Fig. 1) a positive half-wave of the initial sinusoidal signal was formed and the volumes of the solutions of the inner and outer zones were exposed only to the positive potential field of the sinusoidal shape. This provided an abrupt movement of positively charged solvated cations to the electrode with zero charge 7 from the potential positively charged electrode 6 (Figure 4).

The main task was to detect changes in the concentrations of magnesium and calcium cations in solutions of the inner and outer zones in a certain frequency range. Such a fact would indicate the selective transfer of one type of cations from the outer zone to the inner one. In order to ensure the forced transition of cations from the outer zone to the inner zone, the linear velocity of the solution in it must be somewhat higher. A similar mode of solution movement was established using clamps 10 and 11 (Figure No. 3) in each of the experiments. Previously, it was shown [1] that the effects of changing the concentrations of ions in dilute solutions when asymmetric electric fields were applied to them were observed in the frequency range of hundreds of hertz. Considering this circumstance, in this work, the studies were carried out in the frequency range from 10 to 1500 Hz.

In this experiment, the drift of solvated cations is described using the diffusion equation:

$$\frac{\partial^2 C}{\partial x^2} - m \frac{\partial C}{\partial x} + \frac{\partial^2 C}{\partial z^2} - n \frac{\partial C}{\partial z} = 0,$$

$$\frac{\partial C(x,h)}{\partial z} = 0, C(x,0) = C_0, \frac{\partial C(0,z)}{\partial x} - mC(0,z) = 0, \frac{\partial C(l,z)}{\partial x} - mC(l,z) = 0$$

2. PRACTICAL PART

2.1 Analytical solution

To describe the concentration field inside the installation, a second-order partial differential equation (1) was written with boundary conditions (2)-(5):

$$\frac{\partial^2 C}{\partial x^2} - m \frac{\partial C}{\partial x} + \frac{\partial^2 C}{\partial z^2} - n \frac{\partial C}{\partial z} = 0 \quad (1)$$

$$\frac{\partial C(x, h)}{\partial z} = 0 \quad (2)$$

$$C(x, 0) = C_0 \quad (3)$$

$$\frac{\partial C(0, z)}{\partial x} - mC(0, z) = 0 \quad (4)$$

$$\frac{\partial C(l, z)}{\partial x} - mC(l, z) = 0 \quad (5)$$

In this case, the function C has the physical meaning of the ion concentration in the plate layer; it depends on the spatial coordinates of the width and height.

Let's represent the function as a product of two functions, where each depends on only one variable (6):

$$C(x, z) = X(x) \cdot Z(z) \quad (6)$$

Substitute the replacement in the original equation and separate the variables:

$$X''Z - mX'Z + Z''X - nZ'X = 0 \quad (7)$$

$$\frac{X''}{X} - m \frac{X'}{X} = \frac{-Z''}{Z} + n \frac{Z'}{Z} = \lambda \quad (8)$$

We solve the Sturm-Liouville problem for X (12) with boundary conditions (10), (11):

$$\frac{X''}{X} - m \frac{X'}{X} = \lambda \quad (9)$$

$$X'(0) - mX(0) = 0 \quad (10)$$

$$X'(l) - mX(l) = 0 \quad (11)$$

$$X'' - mX' - \lambda X = 0 \quad (12)$$

We write the characteristic equation and consider the cases:

$$k^2 - mk - \lambda = 0 \quad (13)$$

$$k_{1,2} = \frac{m \pm \sqrt{m^2 + 4\lambda}}{2} \quad (14)$$

1) Determinant greater than zero $m^2 + 4\lambda = w^2 > 0$:

The general solution will take the following form:

$$X(x) = C_1 e^{\frac{1}{2}x(m-w)} + C_2 e^{\frac{1}{2}x(m+w)} \quad (15)$$

Calculate the derivative of the function to simplify calculations:

$$X'(x) = \frac{1}{2} \left(e^{\frac{1}{2}x(m-w)} (m-w) C_1 + e^{\frac{1}{2}x(m+w)} (m+w) C_2 \right) \quad (16)$$

Substitute the values from the boundary conditions:

$$\left\{ \begin{array}{l} X(0) = C_1 + C_2 \\ X'(0) = \frac{1}{2}(m-w)C_1 + \frac{1}{2}(m+w)C_2 \end{array} \right\} \quad (17)$$

$$\left\{ \begin{array}{l} X(l) = e^{\frac{1}{2}l(m-w)} C_1 + e^{\frac{1}{2}l(m+w)} C_2 \\ X'(l) = \frac{1}{2} e^{\frac{1}{2}l(m-w)} (m-w) C_1 + \frac{1}{2} e^{\frac{1}{2}l(m+w)} (m+w) C_2 \end{array} \right\} \quad (18)$$

We combine the boundary conditions into a system of equations and find the eigenvalues of the function:

$$(19) \quad \left\{ \begin{array}{l} X'(0) - mX(0) = -\frac{mC_1}{2} - \frac{wC_1}{2} - \frac{mC_2}{2} + \frac{wC_2}{2} = 0 \\ X'(l) - mX(l) = -\frac{1}{2}e^{\frac{1}{2}l(m-w)}mC_1 - \frac{1}{2}e^{\frac{1}{2}l(m-w)}wC_1 - \frac{1}{2}e^{\frac{1}{2}l(m+w)}mC_2 + \frac{1}{2}e^{\frac{1}{2}l(m+w)}wC_2 = 0 \end{array} \right\}$$

Calculate the determinant of the system:

$$\frac{1}{4}e^{\frac{1}{2}l(m-w)}(-1 + e^{lw})(m-w)(m+w)C_1C_2 = 0 \quad (20)$$

Find solutions for which the determinant is equal to zero:

$$w_{1,2,3} = 0, -m, m \quad (21)$$

By condition $w > 0 \Rightarrow w = m$, then:

$$\sqrt{m^2 + 4\lambda} = m \Rightarrow \lambda = 0 \quad (22)$$

We write the general solution, taking into account the found eigenvalues:

$$X_0(x) = C_{10} + C_{20}e^{mx} \quad (23)$$

Let us determine the constants from the boundary conditions:

$$\left\{ \begin{array}{l} X'(0) - mX(0) = -mC_{10} = 0 \\ X'(l) - mX(l) = -mC_{10} = 0 \end{array} \right\} \Rightarrow C_{10} = 0 \quad (24)$$

Taking into account the found constants, we write the general solution:

$$X_0(x) = e^{mx}$$

2) Determinant less than zero $m^2 + 4\lambda = -w^2 < 0 \Rightarrow \sqrt{-m^2 - 4\lambda} = w$:

The general solution will take the following form:

$$X(x) = e^{\frac{mx}{2}} \left(C_1 \cos \left[\frac{x}{2} w \right] + C_2 \sin \left[\frac{x}{2} w \right] \right) \quad (25)$$

Calculate the derivative of the function to simplify calculations:

$$X'(x) = \frac{1}{2} e^{\frac{mx}{2}} \left(\sin \left[\frac{wx}{2} \right] (-wC_1 + mC_2) + \cos \left[\frac{wx}{2} \right] (mC_1 + wC_2) \right) \quad (26)$$

Substitute the values from the boundary conditions:

$$\left\{ \begin{array}{l} X(0) = C_1 \\ X'(0) = \frac{1}{2} (mC_1 + wC_2) \end{array} \right\} \quad (27)$$

$$\left\{ \begin{array}{l} X(l) = e^{\frac{lm}{2}} \left(\cos \left[\frac{lw}{2} \right] C_1 + \sin \left[\frac{lw}{2} \right] C_2 \right) \\ X'(l) = \frac{1}{2} e^{\frac{lm}{2}} \left(\sin \left[\frac{lw}{2} \right] (-wC_1 + mC_2) + \cos \left[\frac{lw}{2} \right] (mC_1 + wC_2) \right) \end{array} \right\} \quad (28)$$

We combine the boundary conditions into a system of equations and find the eigenvalues of the function:

$$\left\{ \begin{array}{l} X'(0) - mX(0) = -\frac{mC_1}{2} + \frac{wC_2}{2} = 0 \\ X'(l) - mX(l) = -\frac{1}{2} e^{\frac{lm}{2}} m \cos \left[\frac{lw}{2} \right] C_1 - \frac{1}{2} e^{\frac{lm}{2}} w \sin \left[\frac{lw}{2} \right] C_1 + \frac{1}{2} e^{\frac{lm}{2}} w \cos \left[\frac{lw}{2} \right] C_2 - \frac{1}{2} e^{\frac{lm}{2}} m \sin \left[\frac{lw}{2} \right] C_2 = 0 \end{array} \right\} \quad (29)$$

Calculate the determinant of the system:

$$\frac{1}{4} e^{\frac{lm}{2}} C_1 C_2 \sin \left[\frac{lw}{2} \right] (m^2 + w^2) = 0 \quad (30)$$

Find solutions for which the determinant is equal to zero:

$$\sin \left[\frac{lw}{2} \right] = 0 \quad (31)$$

$$\frac{lw_k}{2} = \pi k \Rightarrow w_k = \frac{2\pi k}{l} \Rightarrow \sqrt{-m^2 - 4\lambda_k} = \frac{2\pi k}{l} \Rightarrow \lambda_k = -\frac{l}{4} \left(\left(\frac{2\pi k}{l} \right)^2 + m^2 \right), k = \overline{1, \infty}$$

(32)

We write the general solution, taking into account the found eigenvalues:

$$X(x) = e^{\frac{m}{2}x} \left(C_{1k} \cos \left[x \frac{\pi k}{l} \right] + C_{2k} \sin \left[x \frac{\pi k}{l} \right] \right), \lambda_k = -\frac{l}{4} \left(\left(\frac{2\pi k}{l} \right)^2 + m^2 \right) \quad (33)$$

Let us determine the constants from the boundary conditions:

$$\left\{ \begin{array}{l} X'(0) - mX(0) = -\frac{mC_1}{2} + \frac{k\pi C_2}{l} = 0 \\ X'(l) - mX(l) = -\frac{l}{2} e^{\frac{lm}{2}} m \cos[k\pi] C_1 - \frac{\frac{lm}{e^2} k\pi \sin[k\pi] C_1}{l} + \frac{\frac{lm}{e^2} k\pi \cos[k\pi] C_2}{l} - \frac{l}{2} e^{\frac{lm}{2}} m \sin[k\pi] C_2 = 0 \end{array} \right\}$$

(34)

$$\left\{ \begin{array}{l} -\frac{mC_1}{2} + \frac{k\pi C_2}{l} = 0 \\ -\frac{l}{2} m C_1 + \frac{k\pi C_2}{l} = 0 \end{array} \right\} \quad (35)$$

$$C_1 = 2 \frac{k\pi C_2}{ml} \Rightarrow \begin{pmatrix} 1 \\ 2 \frac{k\pi}{ml} \end{pmatrix} \quad (36)$$

Taking into account the found constants, we write the general solution:

$$X_k(x) = e^{\frac{m}{2}x} \left(\cos \left[x \frac{\pi k}{l} \right] + \frac{ml}{2k\pi} \sin \left[x \frac{\pi k}{l} \right] \right) \quad (37)$$

3) The determinant is zero $m^2 + 4\lambda = w = 0$:

The general solution will take the following form:

$$X(x) = C_1 e^{\frac{l}{2}x} + x C_2 e^{\frac{l}{2}x} \quad (38)$$

Calculate the derivative of the function to simplify calculations:

$$X'(x) = \frac{1}{2} e^{\frac{mx}{2}} (C_1 m + C_2 (2 + mx)) \quad (39)$$

Substitute the values from the boundary conditions:

$$\left\{ \begin{array}{l} X(0) = C_1 \\ X'(0) = \frac{1}{2} (C_1 m + 2C_2) \end{array} \right\} \quad (40)$$

$$\left\{ \begin{array}{l} X(l) = C_1 e^{\frac{ml}{2}} + lC_2 e^{\frac{ml}{2}} \\ X'(l) = \frac{1}{2} e^{\frac{ml}{2}} (C_1 m + C_2 (2 + ml)) \end{array} \right\} \quad (41)$$

We combine the boundary conditions into a system of equations and find the eigenvalues of the function:

$$\left\{ \begin{array}{l} X'(0) - mX(0) = \frac{1}{2} (C_1 m + 2C_2) - mC_1 = 0 \\ X'(l) - mX(l) = \frac{1}{2} e^{\frac{ml}{2}} (C_1 m + C_2 (2 + ml)) - m \left(C_1 e^{\frac{ml}{2}} + lC_2 e^{\frac{ml}{2}} \right) = 0 \end{array} \right\} \quad (42)$$

Simplify:

$$\left\{ \begin{array}{l} \frac{1}{2} (C_1 m + 2C_2) - mC_1 = 0 \\ \frac{1}{2} e^{\frac{ml}{2}} (C_1 m + C_2 (2 + ml)) - m \left(C_1 e^{\frac{ml}{2}} + lC_2 e^{\frac{ml}{2}} \right) = 0 \end{array} \right\} \quad (43)$$

$$\left\{ \begin{array}{l} -C_1 \frac{1}{2} m + C_2 = 0 \\ -C_1 \frac{1}{2} e^{\frac{ml}{2}} m + C_2 \left[\frac{1}{2} e^{\frac{ml}{2}} (2 + ml) - m l e^{\frac{ml}{2}} \right] = 0 \end{array} \right\} \quad (44)$$

$$\left\{ \begin{array}{l} -C_1 \frac{l}{2} m + C_2 = 0 \\ -C_1 \frac{l}{2} m + C_2 \left[1 - \frac{ml}{2} \right] = 0 \end{array} \right\} (45)$$

$$-C_1 C_2 \frac{l}{2} m \left[1 - \frac{ml}{2} \right] + C_1 C_2 \frac{l}{2} m = 0 (46)$$

From equation (46) we determine that the system has only trivial solutions, that is, it does not have eigenvalues.

$$-C_1 C_2 \left[1 - \frac{ml}{2} \right] + C_1 C_2 = 0 \Rightarrow C_1 = C_2 = 0 (47)$$

Similarly, we solve the differential equation in Z:

$$Z'' - nZ' + \lambda Z = 0 (48)$$

$$1) \text{ Determinant greater than zero, } n^2 - 4\lambda = q^2 > 0, \lambda = -\frac{1}{4} \left(\left(\frac{2\pi k}{l} \right)^2 + m^2 \right):$$

Then the general solution takes the form:

$$Z(z) = e^{\frac{1}{2}z(n - \sqrt{n^2 - 4\lambda})} C_{11} + e^{\frac{1}{2}z(n + \sqrt{n^2 - 4\lambda})} C_{22} (49)$$

$$Z(z) = e^{\frac{1}{2}z \left(n - \sqrt{n^2 + \left(\frac{2\pi k}{l} \right)^2 + m^2} \right)} C_{11} + e^{\frac{1}{2}z \left(n + \sqrt{n^2 + \left(\frac{2\pi k}{l} \right)^2 + m^2} \right)} C_{22} (50)$$

$$2) \text{ Determinant less than zero, } n^2 - 4\lambda = -q^2 < 0:$$

Then the general solution takes the form:

$$Z(z) = e^{\frac{n}{2}z} \left(C_{22} \cos \left[\frac{z}{2} q \right] + C_{11} \sin \left[\frac{z}{2} q \right] \right) (51)$$

$$3) \text{ The determinant is zero, } n^2 - 4\lambda = -q^2 = 0:$$

Then the general solution takes the form:

$$Z(z) = e^{\frac{l}{2}z} C_{11} + z \cdot e^{\frac{l}{2}z} C_{22} \quad (52)$$

Compose combinations of solutions in X and Z and sum these solutions:

$$\left. \begin{aligned} Z_k(z) &= e^{\frac{l}{2}z \left(n - \sqrt{n^2 + \left(\frac{2\pi k}{l} \right)^2 + m^2} \right)} C_{1k} + e^{\frac{l}{2}z \left(n + \sqrt{n^2 + \left(\frac{2\pi k}{l} \right)^2 + m^2} \right)} C_{2k} \\ X_k(x) &= e^{\frac{m}{2}x} \left(\cos \left[x \frac{\pi k}{l} \right] + \frac{ml}{2k\pi} \sin \left[x \frac{\pi k}{l} \right] \right) \end{aligned} \right\} \quad (53)$$

$$\left. \begin{aligned} X_0(x) &= e^{mx} \\ Z_0(z) &= C_{10} + e^{nz} C_{20} \end{aligned} \right\} \quad (54)$$

$$C(x, z) = e^{mx} (C_{10} + e^{nz} C_{20}) + \sum_{k=1}^{\infty} e^{\frac{m}{2}x} \left(\cos \left[x \frac{\pi k}{l} \right] + \frac{ml}{2k\pi} \sin \left[x \frac{\pi k}{l} \right] \right) \left(e^{\frac{l}{2}z(n-q_k)} C_{1k} + e^{\frac{l}{2}z(n+q_k)} C_{2k} \right) \quad (55)$$

$$\sqrt{n^2 + \left(\frac{2\pi k}{l} \right)^2 + m^2} = q_k \quad (56)$$

Find the remaining constants from the boundary conditions on Z:

$$C(x, z) = e^{mx} (C_{10} + e^{nz} C_{20}) + \sum_{k=1}^{\infty} e^{\frac{m}{2}x} \left(\cos \left[x \frac{\pi k}{l} \right] + \frac{ml}{2k\pi} \sin \left[x \frac{\pi k}{l} \right] \right) \left(e^{\frac{l}{2}z(n-q_k)} C_{1k} + e^{\frac{l}{2}z(n+q_k)} C_{2k} \right) \quad (57)$$

$$C_z(x, z) = e^{mx} e^{nz} n C_{20} + \sum_{k=1}^{\infty} e^{\frac{m}{2}x} \left(\cos \left[x \frac{\pi k}{l} \right] + \frac{ml}{2k\pi} \sin \left[x \frac{\pi k}{l} \right] \right) \left(\frac{l}{2} e^{\frac{l}{2}z(n-q_k)} (C_{1k} (n - q_k) + e^{z q_k} C_{2k} (n + q_k)) \right) \quad (58)$$

$$C(x,0) = C_0 = e^{mx} (C_{10} + C_{20}) + \sum_{k=1}^{\infty} e^{\frac{m^x}{2}} \left(\cos \left[x \frac{\pi k}{l} \right] + \frac{ml}{2k\pi} \sin \left[x \frac{\pi k}{l} \right] \right) (C_{1k} + C_{2k}) \quad (59)$$

$$C_z(x,h) = 0 = e^{mx} e^{nh} n C_{20} + \sum_{k=1}^{\infty} e^{\frac{m^x}{2}} \left(\cos \left[x \frac{\pi k}{l} \right] + \frac{ml}{2k\pi} \sin \left[x \frac{\pi k}{l} \right] \right) \left(\frac{1}{2} e^{\frac{l}{2} h(n-q_k)} (C_{1k}(n-q_k) + e^{hq_k} C_{2k}(n+q_k)) \right) \quad (60)$$

$$\left\{ \begin{array}{l} C_{20} = 0 \\ C_{1k}(n-q_k) + e^{hq_k} C_{2k}(n+q_k) = 0 \end{array} \right\} \Rightarrow C_{1k} = -C_{2k} e^{hq_k} \frac{(n+q_k)}{(n-q_k)} \quad (61)$$

$$C(x,0) = C_0 = C_{10} e^{mx} + \sum_{k=1}^{\infty} e^{\frac{m^x}{2}} \left(\cos \left[x \frac{\pi k}{l} \right] + \frac{ml}{2k\pi} \sin \left[x \frac{\pi k}{l} \right] \right) (C_{1k} + C_{2k}) \quad (62)$$

We expand the function into a generalized Fourier series:

$$C_{10} = \frac{\int_0^l e^{mx} e^{-mx} C_0 dx}{\int_0^l (e^{mx})^2 e^{-mx} dx} = \frac{C_0 l m}{-l + e^{lm}} \quad (63)$$

$$C_{1k} + C_{2k} = \frac{C_0 \int_0^l e^{\frac{m^x}{2}} \left(\cos \left[x \frac{\pi k}{l} \right] + \frac{ml}{2k\pi} \sin \left[x \frac{\pi k}{l} \right] \right) e^{-mx} dx}{\int_0^l \left(\cos \left[x \frac{\pi k}{l} \right] + \frac{ml}{2k\pi} \sin \left[x \frac{\pi k}{l} \right] \right)^2 dx} =$$

$$= C_0 \frac{16 e^{\frac{lm}{2}} k^2 \pi^2 \left(4 e^{\frac{lm}{2}} k l m \pi - 4 k l m \pi \cos[k\pi] + (-l^2 m^2 + 4k^2 \pi^2) \sin[k\pi] \right)}{(l^2 m^2 + 4k^2 \pi^2) (2klm(2+lm)\pi + 8k^3 \pi^3 - 4klm\pi \cos[2k\pi] + (-l^2 m^2 + 4k^2 \pi^2) \sin[2k\pi])}$$

$$\begin{aligned}
& 16e^{-\frac{lm}{2}} k^2 \pi^2 \left(4e^{\frac{lm}{2}} klm\pi - 4klm\pi \cos[k\pi] \right) \\
&= C_0 \frac{\left(4e^{\frac{lm}{2}} klm\pi - 4klm\pi \cos[k\pi] \right)}{\left(l^2 m^2 + 4k^2 \pi^2 \right) \left(2klm\pi (2 + lm) + 8k^3 \pi^3 - 4klm\pi \cos[2k\pi] \right)} = \\
&= C_0 \frac{32e^{-\frac{lm}{2}} k^2 lm\pi^2 \left(e^{\frac{lm}{2}} - \cos[k\pi] \right)}{\left(l^2 m^2 + 4k^2 \pi^2 \right) \left(lm(2 + lm) + 4k^2 \pi^2 - 2lm \right)} = C_0 \frac{32e^{-\frac{lm}{2}} k^2 lm\pi^2 \left(e^{\frac{lm}{2}} - \cos[k\pi] \right)}{\left(l^2 m^2 + 4k^2 \pi^2 \right)^2} \quad (64)
\end{aligned}$$

We compose a system of equations and determine the coefficients:

$$\left\{ \begin{array}{l} C_{1k} = -C_{2k} e^{hq_k} \frac{(n + q_k)}{(n - q_k)} \\ C_{1k} + C_{2k} = C_0 \frac{32e^{-\frac{lm}{2}} k^2 lm\pi^2 \left(e^{\frac{lm}{2}} - \cos[k\pi] \right)}{\left(l^2 m^2 + 4k^2 \pi^2 \right)^2} \end{array} \right\} \quad (65)$$

Eventually:

$$\begin{aligned}
C_{1k} &= -C_{2k} e^{hq_k} \frac{(n + q_k)}{(n - q_k)} \quad (66) \\
C_{2k} &= C_0 \frac{l}{\left(1 - e^{hq_k} \frac{(n + q_k)}{(n - q_k)} \right)} \cdot \frac{32e^{-\frac{lm}{2}} k^2 lm\pi^2 \left(e^{\frac{lm}{2}} - \cos[k\pi] \right)}{\left(l^2 m^2 + 4k^2 \pi^2 \right)^2} \quad (67)
\end{aligned}$$

The general solution takes the form:

$$C(x, z) = C_0 \frac{e^{mx} \cdot lm}{-1 + e^{lm}} + \sum_{k=1}^{\infty} e^{\frac{m^2 x}{2}} \left(\cos \left[x \frac{\pi k}{l} \right] + \frac{ml}{2k\pi} \sin \left[x \frac{\pi k}{l} \right] \right) \left(e^{\frac{1}{2}z(n-q_k)} C_{1k} + e^{\frac{1}{2}z(n+q_k)} C_{2k} \right) \quad (68)$$

2.2 Solution analysis

Initial parameters for plotting concentration distribution graphs in the separation cell of the experimental setup from supplement A:

$$C_0 = 2 \text{ г/л}$$

$$v_{\text{эл}} = 2,5 \cdot 10^{-6} \text{ м/с}$$

$$v_p = 1,67 \cdot 10^{-4} \text{ м/с}$$

$$D = 8,85 \cdot 10^{-7} \text{ м}^2/\text{с}$$

$$h = 0,2 \text{ м}$$

$$l = 3 \cdot 10^{-3} \text{ м}$$

$$m = \frac{v_{\text{эл}}}{D} = 2,82 \text{ м}^{-1}$$

$$n = \frac{v_p}{D} = 188,7 \text{ м}^{-1}$$

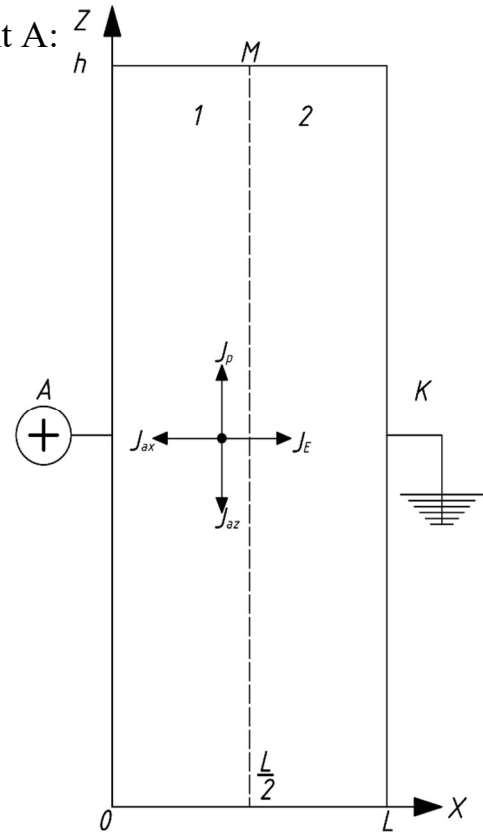

Figure 5. Scheme of the simulated separation cell.

C_0 – initial concentration of ions in solution

$V_{\text{эл}}$ – the average rate of electromigration, which depends on the mobility of the ions-characteristics, current density and electrical conductivity of the solution. It was obtained from the assumption that the translational motion of ions under the action of an alternating half-wave current can be interpreted as the migration of these ions under the action of a direct electric current of a certain magnitude. In this regard, the analysis of the transfer and separation processes realized in an alternating asymmetric electric field can be carried out using the main provisions of the theory of separation of ions according to mobilities in a constant electric field.

V_p – solution velocity (calculated experimentally).

D – diffusion coefficient (calculated experimentally).

h – separator cell height.

l – separation cell length.

Figures 6.7 show graphs of the analytical solution.

Analyzing the graph from Figure 3, we can conclude that the increase in concentration occurs evenly along the OX axis. The increase is 2.5%.

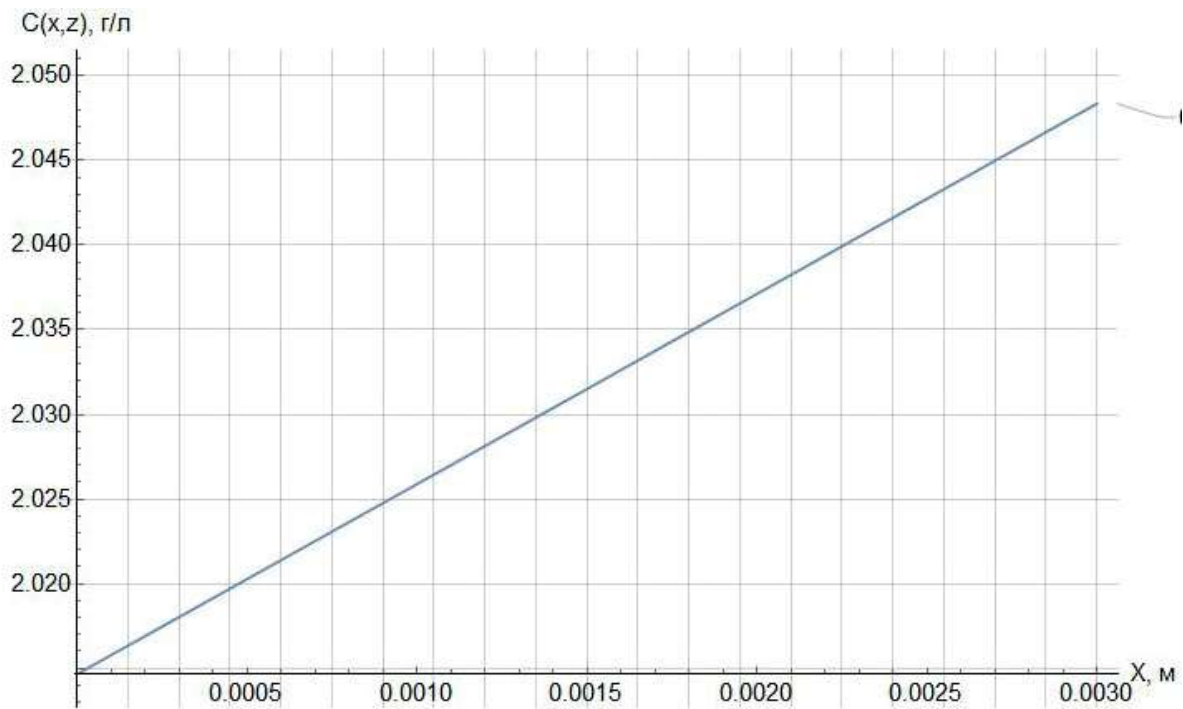

Figure 6. Plot of concentration distribution along the OX axis.

It can be seen from the graph in Figure 7 that the increase in concentration also occurs along the OZ axis. The distribution is even. The increase is 8%.

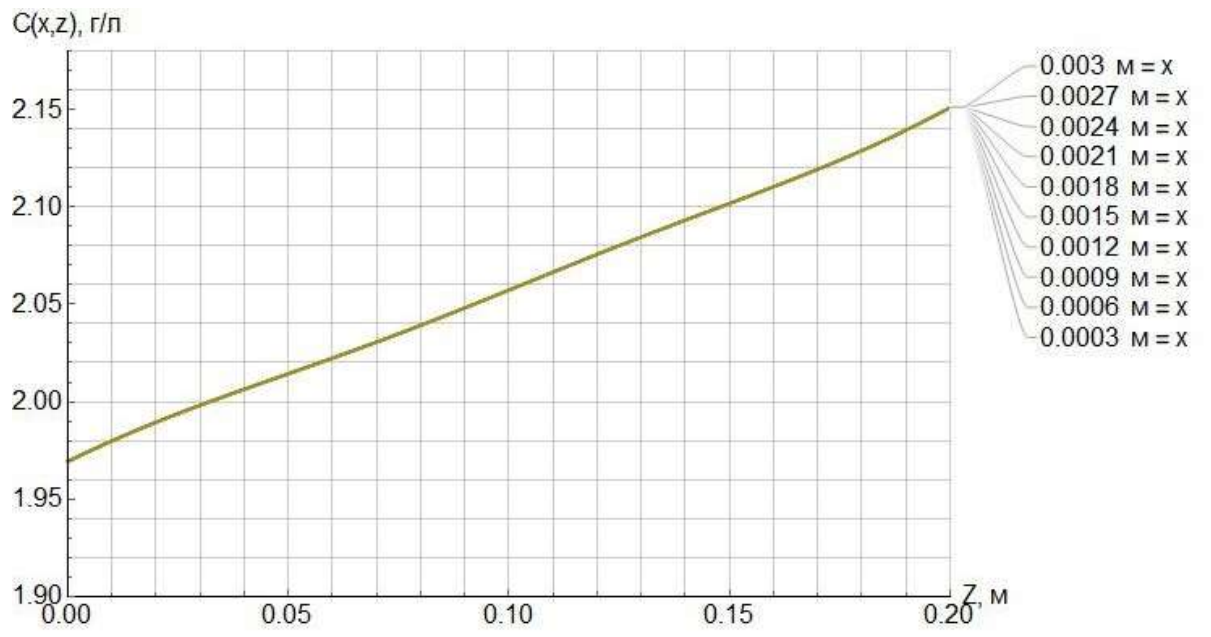

Figure 7. Graph of the distribution of concentration along the OZ axis in different layers of thickness.

2.3 Numerical solution

The simulation was carried out using the Monte Carlo method. The essence of the method is as follows: the initial coordinates of the particle are randomly determined, then, using the probabilistic interpretation presented on the slide, the particle moves through the nodes until it reaches the upper boundary of the cell. Figure 8 schematically shows the area of the separation cell, with a superimposed grid, each node of which has its own integer coordinates.

$$C_0 = 2 \Gamma/\Pi$$

$$v_{\partial n} = 2,5 \cdot 10^{-6} \text{ M/c}$$

$$v_p = 1,67 \cdot 10^{-4} \text{ M/c}$$

$$D = 8,85 \cdot 10^{-7} \text{ M}^2/\text{c}$$

$$h = 0,2 \text{ M}$$

$$l = 3 \cdot 10^{-3} \text{ M}$$

$$N = 10^9, 10^{12} \text{ particles}$$

$$m = \frac{v_{\partial n}}{D} = 2,82 \text{ M}^{-1}$$

$$n = \frac{v_p}{D} = 188,7 \text{ M}^{-1}$$

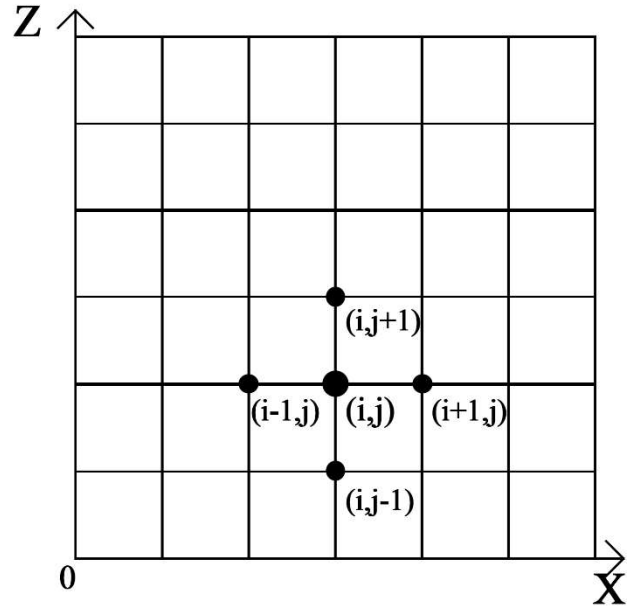

Figure 8. Diagram of a cell with an overlay grid.

As soon as the particle reaches the upper boundary of the cell, the simulation starts again. The probability of moving through the nodes is shown in Figure 9.

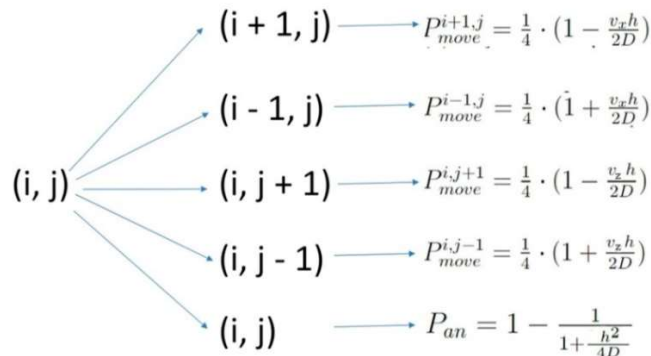

Figure 9. Probabilistic interpretation of particle wandering over nodes.

2.4 Program description

The program is written in the object-oriented C++ programming paradigm for the Linux operating system. The program is built using the CMake system [20]. Program structure: Solver.cpp

- Solver.h
- Data.cpp
- Data.h
- Graphics.cpp
- Graphics.h
- Main.cpp

The Data.cpp and Data.h files contain auxiliary functions for transforming data matrices, generating the position of particles, and determining the position of a particle inside an area. The files also contain initial parameters, such as: length, height, number of nodes in the grid, diffusion coefficient, initial concentration distribution, solution velocity and electromigration rate.

The files Solver.cpp and Solver.h contain a class and its description for determining the concentration field inside the cell (Equation). We list the main functions of the class and their purpose:

1. Function for determining boundary conditions (Boundary_Condition). Activated if the particle has reached one of the edges of the separation cell.
2. The function of determining the coordinates of the particle (walk). Changes the coordinates of the particle depending on the given random number.
3. Coefficient determination function (coff_S, coff_C, coff_D). Depending on what value X and Z takes, one of the functions is called to make a certain contribution to the concentration distribution.
4. Function of establishment of speed (Velocity). Sets the initial wander speeds of the particles.

5. The function of checking for particle reflection (Pr_Jump). If the particle has reached the edge of the separation cell and this edge is not the top one, then the particle bounces off.

The files Graphics.cpp and Graphics.h contain an algorithm that allows you to build graphs of the concentration distribution over the volume of the separation cell.

The Main.cpp file contains the function call and the assembly of the program.

2.5 Simulation results of the concentration field in a separator cell

Figures 10-13 present a graphical representation of the result of the numerical solution.

Figure 10 shows that the main concentration distribution occurs along the Z axis, just as in the case of the analytical solution. Number of simulated particles 10^9 .

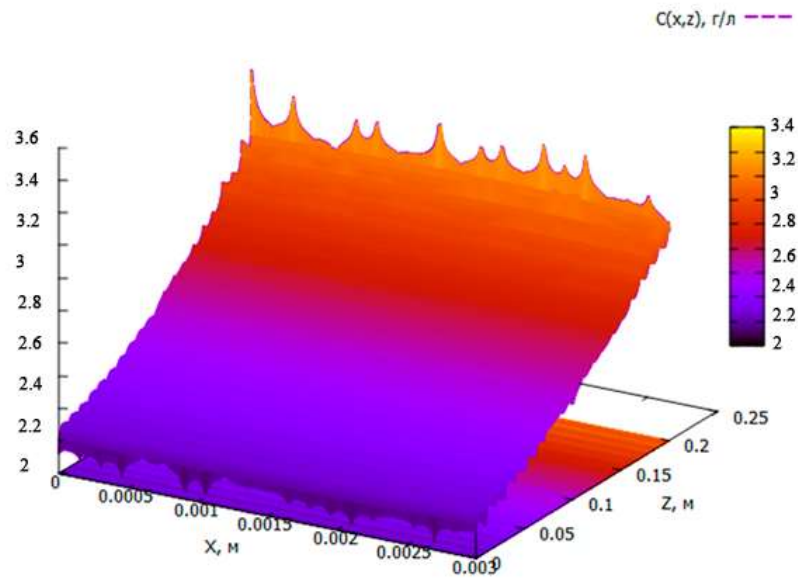

Figure 10. Plot of concentration distribution along the OX and OZ axes. $N = 10^9$.

Figure 11 also shows that the main concentration distribution occurs along the Z axis. With an increase in the number of simulated particles, the accuracy of the solution

increases. This is evidenced by a smoother distribution graph, without pronounced peaks.

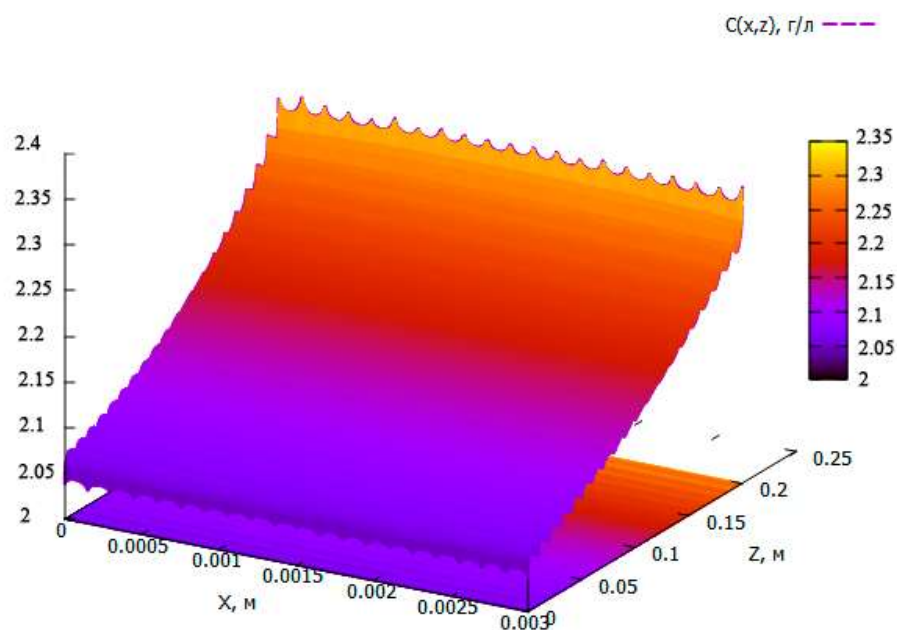

Figure 11. Graph of the distribution of concentration along the axes OX and OZ. $N = 10^{12}$.

Figure 12 shows that the concentration increases by 3.5% along the OX axis. The distribution is linear. The same as in the case of an analytical solution. Number of simulated particles 10^{12} .

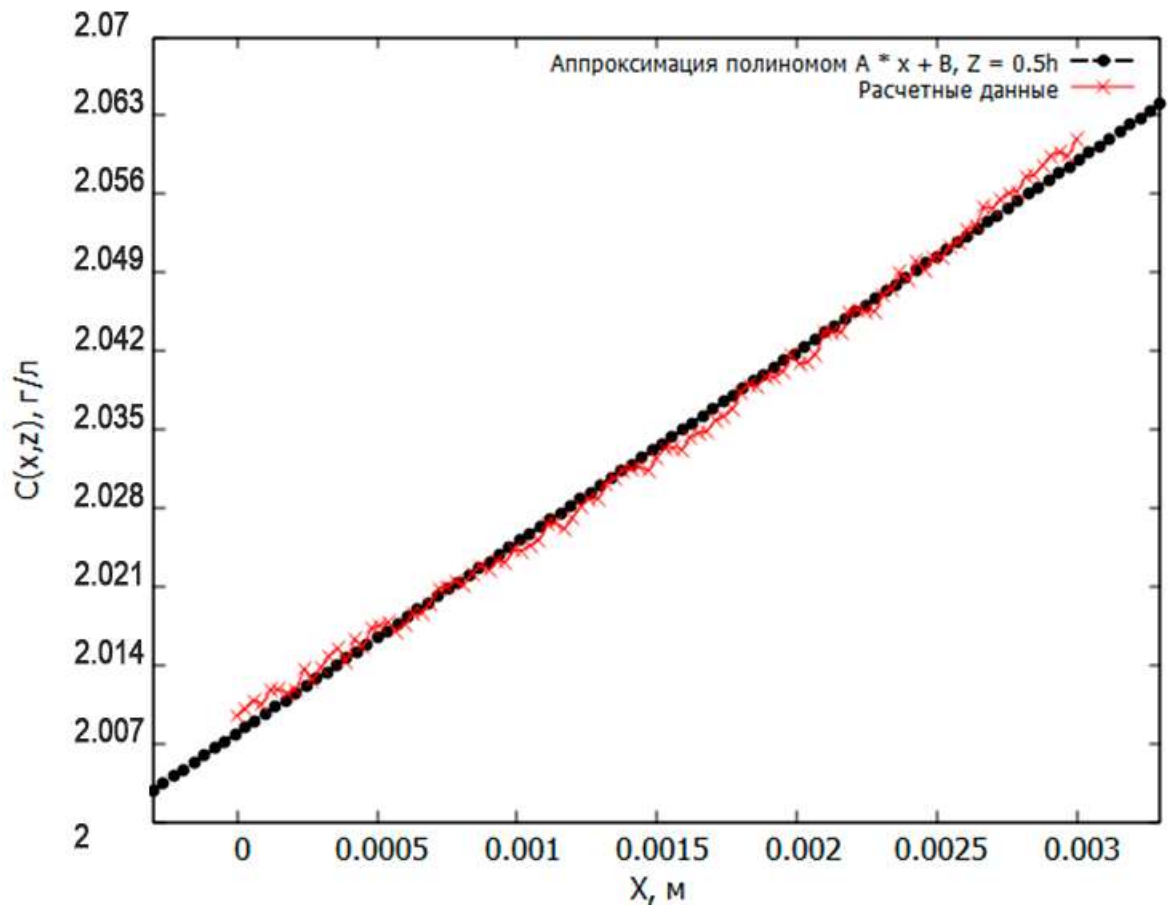

Figure 12. Plot of concentration distribution along the Ox axis. $N = 10^{12}$.

Figure 13 shows that the main concentration distribution also occurs along the Oz axis, this distribution occurs according to a quadratic law. The concentration along the axis increases by 20%. Number of simulated particles 10^{12} .

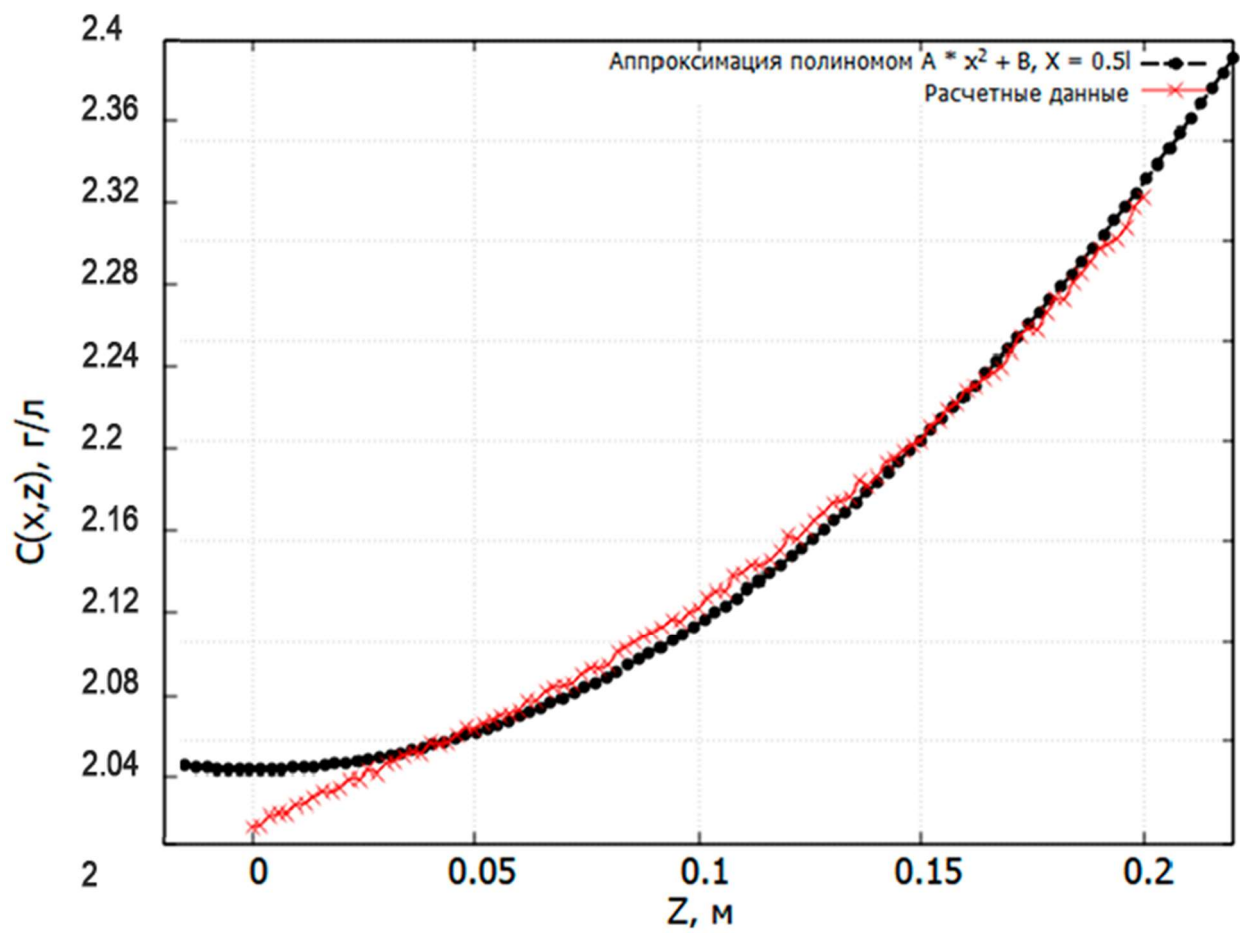

Figure 13. Plot of concentration distribution along the OZ axis. $N = 10^{12}$.

2.6 Model verification

Tables 1 and 2 show a comparison of the concentration values along the OZ axis with a fixed value of X. With the number of simulated particles 109 and 1012.

It can be seen from the tables that with an increase in the number of simulated particles, the absolute difference between the concentration values between the numerical and analytical solution decreases, that is, the numerical solution converges to the analytical one.

Table №1.

| Z, m | $C_A(x = 0,5L, z)$, g/l, analytical | $C_q(x = 0,5L, z)$, g/l , numerical | $ C_A - C_q $, g/l |
|------|---|---|---------------------|
| 0 | 1,94 | 2,52 | 0,58 |
| 0,01 | 1,96 | 2,38 | 0,42 |
| 0,02 | 1,98 | 2,40 | 0,42 |
| 0,03 | 2,00 | 2,72 | 0,72 |
| 0,04 | 2,01 | 2,70 | 0,69 |
| 0,05 | 2,03 | 2,76 | 0,73 |
| 0,06 | 2,04 | 2,86 | 0,82 |
| 0,07 | 2,06 | 2,85 | 0,79 |
| 0,08 | 2,08 | 2,84 | 0,76 |
| 0,09 | 2,10 | 3,00 | 0,9 |
| 0,1 | 2,12 | 2,68 | 0,56 |
| 0,11 | 2,14 | 3,10 | 0,96 |
| 0,12 | 2,15 | 2,94 | 0,79 |
| 0,13 | 2,17 | 2,86 | 0,69 |
| 0,14 | 2,19 | 2,93 | 0,74 |
| 0,15 | 2,21 | 3,41 | 1,2 |
| 0,16 | 2,23 | 3,62 | 1,39 |
| 0,17 | 2,25 | 3,21 | 0,96 |
| 0,18 | 2,27 | 3,12 | 0,85 |
| 0,19 | 2,29 | 3,40 | 1,11 |
| 0,2 | 2,32 | 3,78 | 1,46 |

Table №2.

| Z, m | $C_A(x = 0,5L, z)$, g/l, analytical | $C_q(x = 0,5L, z)$, g/l , numerical | $ C_A - C_q $, g/l |
|------|---|---|---------------------|
| 0 | 1,94 | 2,09 | 0,15 |
| 0,01 | 1,96 | 2,11 | 0,15 |
| 0,02 | 1,98 | 2,14 | 0,16 |
| 0,03 | 2,00 | 2,17 | 0,17 |
| 0,04 | 2,01 | 2,20 | 0,19 |
| 0,05 | 2,03 | 2,23 | 0,2 |
| 0,06 | 2,04 | 2,22 | 0,18 |
| 0,07 | 2,06 | 2,28 | 0,22 |
| 0,08 | 2,08 | 2,27 | 0,19 |
| 0,09 | 2,10 | 2,32 | 0,22 |
| 0,1 | 2,12 | 2,37 | 0,25 |
| 0,11 | 2,14 | 2,41 | 0,27 |
| 0,12 | 2,15 | 2,38 | 0,23 |
| 0,13 | 2,17 | 2,44 | 0,27 |
| 0,14 | 2,19 | 2,46 | 0,27 |
| 0,15 | 2,21 | 2,53 | 0,32 |
| 0,16 | 2,23 | 2,54 | 0,31 |
| 0,17 | 2,25 | 2,58 | 0,33 |
| 0,18 | 2,27 | 2,64 | 0,37 |
| 0,19 | 2,29 | 2,65 | 0,36 |
| 0,2 | 2,32 | 2,67 | 0,35 |

Next, we will calculate the errors using formulas (69)-(72).

$$C_{error}^q(x_i, z_j) = |C_A(x_i, z_j) - C_q(x_i, z_j)| \quad (69)$$

$$\overline{C_{error}^q} = \frac{\sum_{i,j}^{n \cdot k} C_{error}^q(x_i, z_j)}{n \cdot k} \quad (70)$$

$$\overline{C_{error}} = \frac{\sum^N C_{error}^q}{N} \quad (71)$$

$$\sigma = \sqrt{\frac{\sum^N (\overline{C_{error}} - C_{error}^q)^2}{N-1}} \quad (72)$$

Table 3 presents the average error of the numerical solution, the maximum error value is 12.02%, the minimum value is 6.36%. The mean value of the mean errors is 9.01%, the standard deviation is 0.006. Number of simulated particles 10^{12} .

Table №3.

| q | $\overline{C_{error}^q}, \%$ |
|-----|------------------------------|
| 1 | 9,81 |
| 2 | 10,24 |
| 3 | 7,15 |
| 4 | 6,36 |
| 5 | 10,24 |
| 6 | 9,75 |
| 7 | 12,02 |
| 8 | 9,61 |
| 9 | 7,45 |
| 10 | 10,15 |

3. FINANCIAL MANAGEMENT, RESOURCE EFFICIENCY AND RESOURCE SAVING

This graduation qualification thesis is aimed at developing a model and program for modeling the distribution of ion concentration under the influence of electrically induced drift. The purpose of this section is to design and create competitive developments and technologies that meet the requirements in the field of resource efficiency and resource saving.

Achievement of the goal is ensured by solving the following tasks:

- development of the general economic idea of the project, formation of the concept of the project;
- organization of work on a research project;
- identification of possible alternatives for scientific research;
- planning of research works;
- assessment of the commercial potential and the prospects for conducting scientific research from the standpoint of resource efficiency and resource conservation;
- determination of the resource (resource-saving), financial, budgetary, social and economic efficiency of the study [20].

3.1. Potential consumers graduation qualification thesis

The result of the final qualification work is the developed program for modeling the distribution of ion concentration under the influence of electrically induced drift in the installation.

The target market for this work is the nuclear industry, research laboratories with a facility, and nuclear medicine centers where the facility is used.

The service market can be segmented according to the degree of need to use this technique. The segmentation results are presented in Table 4.

Table 4 - Segmentation results

| | | | | |
|------|--------|--|------------------|------------------|
| | | The program for calculating the absorbed dose rate in a room with a gamma installation | | |
| | | Atomic industry | Science industry | Nuclear medicine |
| Need | Strong | | | |
| | Weak | | | |

3.2. Analysis of competitive technical solutions

Analysis of competitive technical solutions allows you to make timely adjustments to the project in order to more successfully resist competitors. Since the markets are in constant motion, it is necessary to periodically conduct such an analysis. The analysis carried out for the developed program is currently presented in Table 5.

Table 5 - Scorecard for comparing competitive technical solutions (developments)

| Criteria for evaluation | Criteria weight | Points | | | Competitiveness | | |
|--|-----------------|------------|----------|----------|-----------------|----------|----------|
| | | B_{ϕ} | B_{K1} | B_{K2} | K_{ϕ} | K_{K1} | K_{K2} |
| 1 | 2 | 3 | 4 | 5 | 6 | 7 | 8 |
| Technical criteria for evaluating resource efficiency | | | | | | | |
| 1. Ease of use | 0.1 | 4 | 2 | 2 | 0.4 | 0.2 | 0.2 |
| 2. Solution Accuracy | 0.2 | 4 | 4 | 3 | 0.8 | 0.8 | 0.6 |
| 3. Memory resource requirement | 0.1 | 2 | 5 | 4 | 0.2 | 0.5 | 0.4 |
| 4. Functional power | 0.1 | 5 | 3 | 2 | 0.5 | 0.3 | 0.2 |
| 5. Versatility | 0.1 | 5 | 4 | 2 | 0.5 | 0.4 | 0.2 |
| Economic criteria for evaluating efficiency | | | | | | | |

| | | | | | | | |
|----------------------------------|------|---|---|---|-------------|-------------|-------------|
| 1. Competitiveness of the method | 0.1 | 3 | 3 | 2 | 0.3 | 0.3 | 0.2 |
| 2. Development costs | 0.2 | 5 | 5 | 5 | 1 | 1 | 1 |
| 3. Estimated service life | 0.05 | 5 | 4 | 4 | 0.25 | 0.2 | 0.2 |
| 4. Development funding | 0.05 | 2 | 2 | 2 | 0.1 | 0.1 | 0.1 |
| Total | 1 | | | | 4.05 | 3.80 | 3.10 |

Analysis of competitive technical solutions is determined by the formula:

$$K = \sum_i B_i \cdot B_i, \quad (73)$$

where K is the development competitiveness;

B_i – indicator weight (in fractions of a unit);

B_i – score of the i -th indicator.

Based on the analysis, it can be concluded that the developed model has the advantage of ease of use, functional power and versatility.

3.3. SWOT-analysis

To conduct a SWOT analysis, we first determine the strengths, weaknesses, opportunities and threats of the project. The result is presented in table 6.

Table 6 - SWOT matrix, first stage

| | | |
|--|---|--|
| | <p>Strengths of the project:</p> <p>C1. Universality of the method</p> <p>C2. Low cost implementation of the method.</p> <p>C3. Setting up calculations using XML files.</p> | <p>Weaknesses of the project:</p> <p>S11. Availability of computers for use.</p> <p>S12. Dependence of accuracy on the number of simulated particles.</p> <p>S13. Dependence of the calculation speed on the number of simulated particles.</p> |
|--|---|--|

| | | |
|--|--|--|
| <p>Capabilities:</p> <p>IN 1. Expanding the capabilities of the calculation model.</p> <p>IN 2. Using the model for research.</p> | | |
| <p>Threats:</p> <p>U1. Lack of demand for new technologies.</p> <p>U2. Probability of development of similar calculation models by other organizations.</p> | | |

Table 7 presents an interactive project matrix, which shows the correlation of strengths with opportunities and weaknesses with threats, which allows you to consider development prospects in more detail.

Table 7 - SWOT matrix, second stage

| | | | | |
|-----------------------|---------------------------|-----|-----|---------------------------|
| Project | Strengths of the project | | | |
| Opportunities | C1 | C2 | C3 | |
| B1 | + | + | + | |
| B2 | + | + | + | |
| Project Opportunities | Weaknesses of the project | | | Weaknesses of the project |
| | Cл1 | Cл2 | Cл3 | |
| B1 | + | - | - | |
| B2 | + | - | - | |
| Project Threats | Strengths of the project | | | |
| | C1 | C2 | C3 | |

| | | | |
|-----------------|---------------------------|-----|-----|
| Y1 | + | + | + |
| Y2 | + | + | + |
| Project Threats | Weaknesses of the project | | |
| | СЛ1 | СЛ2 | СЛ3 |
| Y1 | + | - | - |
| Y2 | + | - | - |

In the matrix of the intersection of strengths and opportunities, it has a certain result: “+” - a strong correspondence between a strength and an opportunity, “-” - a weak ratio, “0” - if there is any doubt about what to put “+” or “-”.

The final SWOT analysis matrix is shown in Table 8:

Table 8 - Final SWOT Matrix

| | | |
|--|--|---|
| | Strengths of the project: C1. Universality of the method C2. Low cost implementation of the method. C3. Setting up calculations using XML files. | Weaknesses of the project: S11. Availability of computers for use. S12. Dependence of accuracy on the number of simulated particles. S13. Dependence of the calculation speed on the number of simulated particles. |
| Capabilities: IN 1. Acceleration of calculations by optimizing the program code. IN 2. Extending the capabilities of the model. | 1. After optimization to increase the calculation speed, the model will be in demand due to its versatility and convenience. | 1. The speed and accuracy of calculations can be increased by optimizing the program code. 2. Expansion of the model's capabilities can be performed without additional equipment. |

| | | |
|--|---|--|
| <p>Threats:</p> <p>U1. Lack of demand for new technologies.</p> <p>U2. Probability of development of similar calculation models by other organizations.</p> | <p>1. The versatility of the method, the convenience of setting up the calculation can cause a demand for the technology.</p> | <p>1. Currently, computer simulation is a cheap research method, which has significantly increased the demand for such technologies.</p> |
|--|---|--|

Thus, at the moment, the advantages of the developed model are such as the accuracy of the data obtained, the possibility of optimizing the model, cost-effectiveness, accessibility, ease of use, the possibility of obtaining data using only a computer.

3.4. Project Planning

The work on the topic includes the following steps:

- 1) Preparation of terms of reference;
- 2) Study of the problem, literature review;
- 3) Scheduling work;
- 4) Building a model;
- 5) Writing program code;
- 6) Obtaining the results of particle concentration distribution under the action of electrically induced drift, verification;
- 7) Registration of the report.

To carry out the final qualifying work, a working group was formed, which includes a supervisor and a student.

To optimize work, it is convenient to use the classical method of linear planning and control. The result of such planning is the preparation of a linear schedule for the implementation of all work. The calculation of the parameters of the linear schedule requires the determination of the duration of the work. In the absence of time standards for carrying out certain types of work, probabilistic estimates are used. The procedure for compiling stages and works is given in Table 9.

Table 9 - List of stages, works and distribution of performers

| Main steps | № | Content of works | Position of the performer |
|--|----------|---|----------------------------------|
| Task development | 1 | Preparation of terms of reference | scientific director |
| Choice of research direction | 2 | Study of the problem, literature review | scientific adviser, student |
| | 3 | Work scheduling | student |
| Theoretical and experimental studies | 4 | Model building | scientific adviser, student |
| | 5 | Writing code | |
| | 6 | Obtaining the results of particle concentration distribution under the action of electrically induced drift, verification | scientific adviser, student |
| Generalization and evaluation of results | 7 | Report design | student |

3.4.1. Determination of the complexity of performing graduation qualification thesis

To optimize the work, we use the classical method of linear planning and control, as a result, we will draw up a linear schedule for the execution of all work.

To determine the labor costs, it is first necessary to set the minimum possible complexity of the stage and the maximum possible, then the expected labor intensity is determined by the formula:

$$t_{ожсi} = \frac{3t_{мини} + 2t_{максi}}{5} \quad (74)$$

The duration of work in working days is determined as follows:

$$T_{pi} = \frac{t_{ожсi}}{q_i} \quad (75)$$

where U_i – the number of performers performing the same work at the same time at the stage, pers.

3.4.2 Development of a schedule for graduation qualification thesis

Since the project is relatively small, it is optimal to build a tape schedule of work for greater clarity and convenience. The Gantt chart is a horizontal strip chart, on which the work on the topic is presented as long time intervals, characterized by the start and end dates of the work.

Before building a Gantt chart, let's determine the duration of the work of each stage in calendar days. The calculation begins with the determination of the calendar factor:

$$k = \frac{T_{\text{кал}}}{T_{\text{кал}} - T_{\text{вых}} - T_{\text{пр}}}, \quad (76)$$

where $T_{\text{кал}}$ – the number of calendar days in a year;

$T_{\text{вых}}$ – the number of days off in a year;

$T_{\text{пр}}$ – the number of holidays in a year.

$$k = \frac{366}{366 - 104 - 14} = 1,478$$

Knowing the coefficient, you can determine the duration of work in calendar days:

$$T_{ki} = T_{pi} \cdot k \quad (77)$$

Using the above formulas, we will issue the calculation in the form of table 10:

Table 10 - Time indicators for the implementation of an engineering project

| Stage | Labor intensity of work | | | Performers | Duration of work in working days T_{pi} | Duration of work in calendar days T_{ki} |
|-------|----------------------------|----------------------------|---------------------------|------------|--|---|
| | t_{min} , чел-дни | t_{max} , чел-дни | $t_{\text{ож}}$, чел-дни | | | |
| 1 | 4 | 6 | 4.8 | Н.р. | 4.8 | 8 |
| 2 | 7 | 12 | 9 | Н.р.+с. | 4.5 | 7 |

| | | | | | | |
|--------------|----|----|------|---------|------|----|
| 3 | 4 | 6 | 4.8 | c. | 4.8 | 8 |
| 4 | 10 | 14 | 11.6 | H.p.+c. | 5.8 | 9 |
| 5 | 14 | 20 | 16.4 | c. | 16.4 | 25 |
| 6 | 7 | 14 | 9.8 | H.p.+c. | 4.9 | 8 |
| 7 | 7 | 10 | 8.2 | c. | 8.2 | 13 |
| Total | | | | | | 78 |

Based on table 10, a Gantt chart was built, which is presented in table 11.

Table 11 - Calendar schedule (Gantt chart) for graduation qualification thesis

| № | Type of work | Performers | T _k , cal. days | Duration of work, week | | | | | | | | | | |
|---|---|------------|----------------------------|------------------------|---|---|-------|---|---|-----|---|---|---|--|
| | | | | March | | | April | | | May | | | | |
| | | | | 1 | 2 | 3 | 1 | 2 | 3 | 1 | 2 | 3 | | |
| 1 | Compiling a task | н.п. | 8 | █ | | | | | | | | | | |
| 2 | Study of the problem, literature review | н.п.+с. | 7 | | █ | | | | | | | | | |
| 3 | Work scheduling | с. | 8 | | | █ | █ | | | | | | | |
| 4 | Model building | н.п.+с. | 9 | | | | █ | █ | | | | | | |
| 5 | Writing code | с. | 25 | | | | | █ | █ | █ | █ | | | |
| 6 | Obtaining the particle concentration distribution of electrically induced drift, verification | н.п.+с. | 8 | | | | | | | | | █ | █ | |

3.5. Project's budget

The project budget consists of material costs, the basic salary of graduation qualification thesis performers, deductions to off-budget funds and overhead costs.

3.5.1. Material costs

The calculation of material costs is made according to the formula:

$$C_M = (1 + k_T) \sum_{i=1}^m U_i \cdot N_{pacxi}, \quad (78)$$

where m – the number of types of material resources consumed during the execution of graduation qualification thesis;

N_{pacxi} – the amount of material resources planned to be used when performing graduation qualification thesis;

U_i – price of a material resource per unit;

k_T – coefficient taking into account transportation and procurement costs, the value of which varies from 15 to 25%.

Electricity costs are calculated as follows:

$$C = U_{эл} \cdot P \cdot F_{об}, \quad (79)$$

where $U_{эл}$ – electricity tariff, for Tomsk for 2022 the tariff is 3.85 rubles / (kWh);

P – power of the equipment, the used equipment has a power supply of 180 watts.

$F_{об}$ – equipment usage time, usage time 496 hours.

Calculation:

$$C = 3.85 \cdot 0.18 \cdot 496 = 343.73 \text{ руб.}$$

Table 12 - Material costs

| Name | Quantity, pcs. | Unit price, rub. | C _M , rub. |
|--------------|----------------|------------------|-----------------------|
| Paper A4 | 1 | 250 | 250 |
| Electricity | 89.3 | 3.85 | 343.73 |
| Total | | | 593.73 |

3.5.2. Special Equipment Costs

Graduation qualification thesis used personal equipment. calculate the amount of depreciation:

$$C_a = \sum_{i=1}^n \frac{U_{\text{бал}} \cdot H_a \cdot g_i \cdot t}{\Phi_{\text{эф}}}, \quad (80)$$

where $U_{\text{бал}}$ – cost of the type of equipment;

H_a – annual depreciation rate;

g_i – number of pieces of equipment;

t – equipment operating time;

$\Phi_{\text{эф}}$ – effective fund of equipment operation time;

In work, the special equipment is a laptop worth 50,000 rubles. Depreciation rate 25%. Equipment use time $62 \cdot 8 / 24 = 21$ days.

$$C_a = \frac{50000 \cdot 0.25 \cdot 1 \cdot 21}{251} = 1046 \text{ руб.}$$

3.5.3. Salary of graduation qualification thesis performers.

The salary of graduation qualification thesis performers consists of the main and additional:

$$C_{\text{зн}} = \text{З}_{\text{осн}} + \text{З}_{\text{дон}} \quad (81)$$

The basic salary can be defined as follows:

$$\text{З}_{\text{осн}} = \text{З}_{\text{дн}} \cdot T_{\text{раб}}, \quad (82)$$

where $\text{З}_{\text{дн}}$ – worker's average daily wage;

$T_{\text{раб}}$ – duration of works.

The average daily wage of an employee is determined by the formula:

$$\text{З}_{\text{дн}} = \frac{\text{З}_M \cdot M}{F_D} \quad (83)$$

where З_M – employee's monthly salary;

M – number of months of work without vacation during the year (10.4 months, with vacation of 48 working days, 6-day week);

F_D – estimated annual fund of staff working time.

Table 13 - Estimated annual working time fund

| Working time indicators | Supervisor | Student |
|-----------------------------------|-------------------|----------------|
| Calendar number of days | 365 | 365 |
| Number of non-working days | | |
| -weekend | 52 | 52 |
| -holidays | 14 | 14 |
| Loss of working time | | |
| -vacation | 48 | 48 |
| - absenteeism due to illness | - | - |
| Valid annual fund of working time | 251 | 251 |

Calculation of the average daily salary and basic salary for a supervisor (salary of an associate professor, candidate of science 37,700 rubles):

$$Z_{\text{дн}} = \frac{49010 \cdot 10.4}{251} = 2030.7 \text{ руб.}$$

$$Z_{\text{осн}} = 2030.7 \cdot 32 = 64982.4 \text{ руб.}$$

For a student (in calculations, it is assumed that the student's salary is taken equal to the minimum wage of 13,890 rubles):

$$Z_{\text{дн}} = \frac{18057 \cdot 10.4}{251} = 748.2 \text{ руб.}$$

$$Z_{\text{осн}} = 748.2 \cdot 70 = 52374 \text{ руб.}$$

Table 14 - Calculation of the basic salary

| Performers | $Z_{\text{ТС}}$, rub. | k_p | Z_M, rub. | $Z_{\text{дн}}$, rub | T_p, rub.days. | $Z_{\text{осн}}$, rub. |
|--------------------|---|-------------------------|-------------------------------|--|--|--|
| Scientific adviser | 37700 | 1,3 | 49019 | 2030.7 | 32 | 64982.4 |
| Student | 13890 | 1,3 | 18057 | 748.2 | 70 | 52374 |
| Total | | | | | | 89212 |

The costs of additional wages for the performers of the topic take into account the amount of additional payments provided for by the Labor Code of the

Russian Federation for deviations from normal working conditions, as well as payments related to the provision of guarantees and compensations (when performing state and public duties, when combining work with education, when providing annual paid leave etc.).

$$Z_{\text{доп}} = k_{\text{доп}} \cdot Z_{\text{осн}} \quad (84)$$

where $Z_{\text{доп}}$ – additional salary, rub.;

$k_{\text{доп}} = 0.14$ – additional salary ratio;

$Z_{\text{осн}}$ – basic salary, rub.

Table 15 - Salaries of graduation qualification thesis performers

| Wage | Supervisor | Student |
|---|------------|---------|
| Basic salary $Z_{\text{осн}}$, rub. | 64982.4 | 52374 |
| Additional salary $Z_{\text{доп}}$, rub. | 9097.5 | 7332.4 |
| Total for item $Z_{\text{зп}}$, rub. | 74079.9 | 59706.4 |
| Total | 133786.3 | |

3.5.4. Deductions to off-budget funds

The amount of deductions to off-budget funds is determined by the formula:

$$C_{\text{внеб}} = k_{\text{внеб}} \cdot Z_{\text{общ}} \quad (85)$$

where $k_{\text{внеб}}$ – the coefficient of deductions for payment to off-budget funds varies from 30 to 35%. When calculating, we will assume that $k_{\text{внеб}} = 30.2\%$ for educational and scientific institutions.

From the previous paragraphs, $Z_{\text{tot}} = 133786.3$ rubles. Then the amount of deductions will be:

$$C_{\text{внеб}} = 0.302 \cdot 133786.3 = 40403.5 \text{ руб.}$$

3.5.5. Overheads

Overhead costs are calculated using the formula:

$$C_{\text{накл}} = k_{\text{накл}} \cdot Z_{1-3} \quad (86)$$

where $k_{\text{накл}}$ – overhead cost ratio, in the calculation we will take equal to 16%.

$$C_{\text{накл}} = 0.16 \cdot 135426.0 = 21668.2 \text{ руб.}$$

3.5.5. Formation of the cost budget graduation qualification thesis

Based on the calculations, we will compile a table with the resulting graduation qualification thesis costs.

Table 16 - Graduation qualification thesis cost budget

| Expenses | Amount, rub. |
|--------------------------------|------------------|
| Material costs | 593.73 |
| Special Equipment Costs | 1046 |
| Project executor salary | 133786.3 |
| Deductions to off-budget funds | 40403.5 |
| Overheads | 21668.2 |
| Total | 197497.73 |

3.6. Determination of resource (resource-saving) efficiency graduation qualification thesis

3.6.1. Evaluation of the scientific and technical effect

The assessment of the scientific and technical effect is based on the coefficient of the socio-scientific effect:

$$H_T = \sum_{i=1}^3 r_i k_i \quad (87)$$

where r_i – weight coefficient of the i-th feature of the scientific and technical effect;

k_i – quantitative assessment of the i-th feature.

Table 17 - Weight coefficients of signs of scientific and technical effect

| Signs of scientific and technological effect | Approximate weighting values |
|--|------------------------------|
| Novelty level | 0.6 |

| | |
|-------------------------------|-----|
| Theoretical level | 0.4 |
| Possibility of implementation | 0.2 |

Table 18 - Novelty level scores

| Novelty level | Characteristics of the level of novelty | Points |
|----------------|--|--------|
| Fundamental | Research results open a new direction in this field of science and technology | 8-10 |
| New | Known facts, patterns are explained in a new way or for the first time | 5-7 |
| Relatively new | Research results systematize and summarize the available information, determine the ways for further research | 2-4 |
| Traditional | The work performed according to the traditional method, the results of the research are for informational purposes | 1 |
| No novelty | The result was obtained, which was previously known | 0 |

Table 19 - Significance scores of theoretical levels

| Theoretical level of the obtained results | Points |
|---|--------|
| Establishment of the law; development of a new theory | 9-10 |
| Deep development of the problem: multidimensional analysis of relationships, interdependence between facts with the presence of an explanation | 7-8 |
| Development of a method (algorithm, program of events, device, innovation, etc.) | 3-6 |
| Elementary analysis of relationships between facts with the presence of a hypothesis, simplex forecast, classification, explanation of versions or practical recommendations of a particular nature | 0.6-2 |

| | |
|--|-------|
| Description of individual elementary facts (things, properties and relationships); presentation of experience, observations, measurement results | 0-0.5 |
|--|-------|

Table 20 - Probability of implementation by time and scale of implementation

| Implementation time | Points |
|-------------------------|--------|
| During the first years | 5-10 |
| 5 to 10 years | 3-4 |
| Over 10 years | 0-2 |
| Scale of implementation | Points |
| One or more businesses | 0-2 |
| Industry (Ministry) | 3-4 |
| National economy | 5-10 |

The project is evaluated as follows:

- novelty level score - 3
- significance score of the theoretical level - 6
- score on the probability of realization - 5+2=7

$$H_T = 0.6 \cdot 3 + 0.4 \cdot 6 + 0.2 \cdot 7 = 5.6$$

Table 21 - Assessment of the level of scientific and technical effect

| The level of scientific and technological effect | Coefficient of scientific and technical effect |
|--|--|
| Short | 1-4 |
| Average | 5-7 |
| Relatively high | 8-10 |
| High | 11-14 |

Based on Table 21, the level of scientific and technical effect is medium.

3.6.2. Evaluation of the comparative effectiveness of the study

One of the execution options is to write a program not in C ++, MatLab, but in Python, which is easier to learn, and programs are written faster, but it is an interpreted language, which makes it difficult to debug the program, since errors are detected at the stage interpretation of the computer code, as well as the calculation speed is less (Analogue 1). Another option for graduation qualification thesis is to write a program using special libraries for Monte Carlo calculations (Analogue 2). The final budget for the graduation qualification thesis options is summarized in Table 22.

Table 22 - Budget options

| Project | Budget, rub. | Integral financial indicator of development |
|-----------------|---------------------|--|
| Current project | 197497.73 | 0.77 |
| Analogue 1 | 160127.541 | 0.63 |
| Analogue 2 | 255785.394 | 1 |

Table 23 - Comparative evaluation of the characteristics of options

| Criteria | Parameter weighting factor | Current project | Analogue 1 | Analogue 2 |
|--------------------------------|-----------------------------------|------------------------|-------------------|-------------------|
| 1. Ease of operation | 0.1 | 4 | 4 | 5 |
| 2. Solution accuracy | 0.3 | 4 | 4 | 3 |
| 3. Demand for memory resources | 0.2 | 2 | 1 | 1 |
| 4. Functional power | 0.2 | 5 | 2 | 4 |
| 5. Versatility | 0.2 | 5 | 5 | 4 |

$$I_{mn} = 0.1 \cdot 4 + 0.3 \cdot 4 + 0.2 \cdot 2 + 0.2 \cdot 5 + 0.2 \cdot 5 = 4$$

$$I_1 = 0.1 \cdot 4 + 0.3 \cdot 4 + 0.2 \cdot 1 + 0.2 \cdot 2 + 0.2 \cdot 5 = 3.2$$

$$I_2 = 0.1 \cdot 5 + 0.3 \cdot 3 + 0.2 \cdot 1 + 0.2 \cdot 4 + 0.2 \cdot 4 = 3.2$$

Table 24 - Comparative development efficiency

| Project | Current project | Analogue 1 | Analogue 2 |
|---|------------------------|-------------------|-------------------|
| Integral financial indicator | 0.77 | 0.63 | 1 |
| Integral indicator of resource efficiency | 4 | 3.2 | 3.2 |
| Integral efficiency indicator | 5.19 | 5.08 | 3.2 |
| Comparative efficiency of variants | - | 1.02 | 1.62 |

Based on table 24, we can conclude that the current project is the most effective. The differences from analog 1 are not so big, a feature of analog 1 is the implementation of graduation qualification thesis with lower budget costs, however, the functional capacity of the development is much less than the current execution. Thus, it is optimal to leave the current execution.

Section Conclusions

1. The analysis of competitive technical solutions showed that the developed model has an advantage in ease of use, functional power and versatility.
2. The advantages of the developed model, such as the accuracy of the data obtained, the possibility of optimizing the model, cost-effectiveness, accessibility, ease of use, the possibility of obtaining data using only a computer.
3. The project budget was 197497.73 rubles.
4. The level of scientific and technological effect is average.

4. SOCIAL RESPONSIBILITY

The result of the final qualifying work is the developed program in C++ for determining the concentration field in the volume of the separation cell of the experimental setup. The unit is designed to separate ions in aqueous solutions of their electrolytes. The WRC was held in room 102 of building 11 of Tomsk Polytechnic University.

The section discusses dangerous and harmful factors that affect the research process, considers the impact of the object under study on the environment, legal and organizational issues, as well as measures in emergency situations.

4.1 Legal and organizational issues of security

4.1.1. Special (characteristic for the researcher's working area) legal norms of labor legislation

The main provisions on labor protection are set out in the Labor Code of the Russian Federation [22]. This document states that the protection of the health of workers, the provision of safe working conditions, the elimination of occupational diseases and industrial injuries are one of the main concerns of the state.

According to [22], each employee has the right to:

- a workplace that meets the requirements of labor protection;
- compulsory social insurance against industrial accidents and occupational diseases;
- obtaining reliable information from the employer, relevant state bodies and public organizations about the conditions and labor protection at the workplace, about the existing risk of damage to health, as well as about measures to protect against exposure to harmful and (or) dangerous production factors;
- refusal to perform work in case of danger to his life and health due to violation of labor protection requirements;
- provision of means of individual and collective protection in accordance with the requirements of labor protection at the expense of the employer;

– training in safe working methods and techniques at the expense of the employer;

- personal participation or participation through their representatives in the consideration of issues related to ensuring safe working conditions at his workplace, and in the investigation of an accident at work or an occupational disease that happened to him;

- an extraordinary medical examination in accordance with medical recommendations, while retaining his place of work (position) and average earnings during the passage of the specified medical examination;

– guarantees and compensations established in accordance with this Code, a collective agreement, an agreement, a local normative act, an employment contract, if he is employed in work with harmful and (or) dangerous working conditions.

The Labor Code of the Russian Federation states that the normal working hours cannot exceed 40 hours per week, the employer is obliged to keep records of the time worked by each employee [23].

4.1.2. Special (characteristic for the researcher's working area) legal norms of labor legislation

A rational layout of the workplace provides for a clear order and consistency in the placement of objects, means of labor and documentation. What is required to perform the work more often should be located in the zone of easy reach of the workspace, as shown in Figure 32.

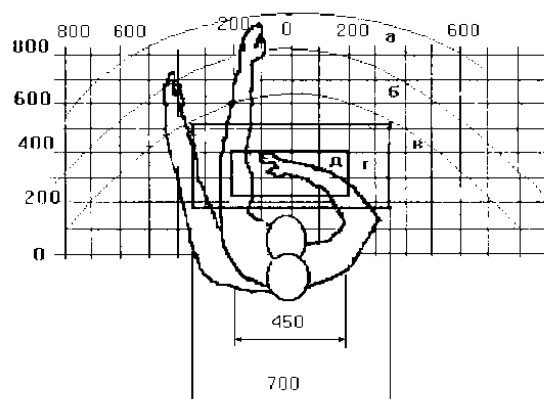

Figure 32 - Hand reach areas in the horizontal plane:

a - the zone of maximum reach of the hands; b - the reach zone of the fingers with an outstretched hand; c - zone of easy reach of the palm; g - the optimal space for rough manual work; e - optimal space for fine handwork

Optimal placement of objects of work and documentation within the reach of hands:

- the display is located in zone a (in the center);
- keyboard – in zone d, e;
- the system unit is located in zone b (on the left);
- the printer is in zone a (on the right);
- literature and documentation required for work is within easy reach of the palm - in (left);
- in the drawers of the table - literature that is not used constantly [24].

When choosing a workplace, namely a desk, the following requirements should be taken into account [24], which are presented in Table 26.

Table 25 - Requirements for equipping a workplace that provides for long-term work at a PC

| | |
|---|---|
| Desktop width | 80 to 140 cm |
| Desktop height | 75 cm |
| Desktop depth | 60 to 80 cm |
| Distance from eyes to monitor | 50 to 60 cm |
| Distance of the keyboard from the edge of the table | 10 to 30 cm |
| Seat | Should allow adjustment in height, swivel and angle of the backrest (adjustments should be independent of each other) |
| Legroom | Width from 30 cm, depth - from 40 cm, with an angle of inclination up to 20 degrees |

The monitor should be located at the operator's eye level at a distance of 500-600 mm. According to the standards, the viewing angle in the horizontal plane should be no more than 45 degrees to the normal of the screen. It is better if the

viewing angle is 30 degrees. In addition, it should be possible to select the level of contrast and brightness of the image on the screen [24].

It should also be possible to adjust the monitor screen:

- in height +3 cm;
- inclination relative to the vertical 10 - 20 degrees;
- in left and right directions.

If the operator's work involves monotonous mental work that requires significant nervous tension and great concentration, then it is best to choose soft, low-contrast color shades (weakly saturated shades of cold blue or green colors), which do not weaken attention. If the work requires a lot of mental and physical stress, then you should use warmer shades that help increase concentration [24].

4.2 Legal and organizational issues of security

4.2.1. Analysis of harmful and dangerous factors

The production conditions at the place of work are characterized by the presence of dangerous and harmful factors, which, by the nature of their occurrence, are divided into the following groups:

- physical;
- chemical;
- psychophysiological;
- biological [25].

Dangerous and harmful factors that may affect personnel when working on a PC are shown in Table 27.

Table 26 - Dangerous and harmful factors in laboratory № 102 11 of the TPU building

| Name of types of work and parameters of the production process | Factors | | Regulations |
|--|---------|-------------|--|
| | Harmful | Dangerous | |
| Calculation of data on a PC | - | Electricity | GOST 12.1.038-82 SSBT. Electrical safety [26], |

| | | | |
|--|---|-------------|--|
| | Exposure to radiation (HF, UHF, microwave, etc.). | - | SanPiN 2.2.4/2.1.8.055-96. Electromagnetic radiation in the radio frequency range [27]. |
| | - | Fire hazard | GOST 12.1.004-91 SSBT. Fire safety [28]. |
| | Noise, vibration, microclimate | - | SanPiN 1.2.3685-21 "Hygienic standards and requirements for ensuring the safety and (or) harmlessness of environmental factors for humans" [25]. |

The psychologically harmful factors affecting the staff include:

- neuro-emotional overload;
- mental stress;
- physical overload.

4.3 Justification of measures to protect the researcher from the action of harmful and dangerous factors

In accordance with the basic requirements for the premises for the operation of a PC [25], they must have natural and artificial lighting. The area per workplace of PC users should be at least 6 m².

4.3.1. Deviation of microclimate indicators

The air of the working area (microclimate) of industrial premises is determined by the following parameters: temperature, relative humidity, air velocity. The optimal values of the microclimate characteristics are set in accordance with the standards and are given in table 28.

Table 27 - Optimal microclimate parameters

| Period of the year | Temperature, °C | Relative humidity, % | Air speed, m/s |
|--------------------|-----------------|----------------------|----------------|
| Cold | 23-25 | 40-60 | 0,1 |
| Warm | 22-24 | 40 | 0,1 |

Deviation of microclimate indicators from the norm does not cause damage or health disorders, but can lead to general and local sensations of thermal discomfort, tension in thermoregulation mechanisms, deterioration in well-being and decreased performance [25].

To ensure the established norms of microclimatic parameters and air purity at workplaces and in rooms, ventilation is used.

Ventilation can be carried out naturally and mechanically. The optimal frequency of air exchange in industrial premises is within a fairly wide range: from 3 to 40 times per hour [25].

According to [29], the room requires an air exchange rate of 40 m³/h per person. The office in which the work was performed is designed for 7 workplaces, so the ventilation performance will be:

$$L = k \cdot Q = 7 \cdot 40 = 280 \frac{\text{M}^3}{\text{ч}} \quad (88)$$

where k – is the number of people;

Q – air exchange rate per person.

This performance is provided by a Vents 150 VKO fan with a maximum capacity of 298 m³/h and a power of 24 W [30].

Thus, the microclimate indicator in room 102 of TPU building 11 complies with the established standards [25].

4.3.2. Increased level of electromagnetic radiation

Electromagnetic radiation is a perturbation (change of state) of the electromagnetic field propagating in space.

The screen and system blocks of the computer produce electromagnetic radiation. Its main part comes from the system unit and video cable. The strength of the electromagnetic field at a distance of 50 cm around the screen in terms of the electrical component must comply with Table 29.

An increased level of electromagnetic radiation can negatively affect the human body, namely, lead to nervous disorders, sleep disturbance, a significant

deterioration in visual activity, weakening of the immune system, and disorders of the cardiovascular system [27].

Table 28 - Permissible levels of electromagnetic field parameters

| Name of parameters | | Acceptable level value |
|--------------------------------|---------------------------------|------------------------|
| Electromagnetic field strength | Frequency range 5 Hz -2 kHz | 25 V/m |
| | Frequency range 2 kHz - 400 kHz | 2,5 V/m |
| Magnetic flux density | Frequency range 5 Hz -2 kHz | 250 nTl |
| | Frequency range 2 kHz - 400 kHz | 25 nTl |

There are the following ways to protect against EMF:

- increasing the distance from the source (the screen must be at least 50 cm away from the user);
- the use of near-screen filters, special screens and other personal protective equipment [27].

4.3.3. Insufficient illumination of the working area

Fatigue of the organs of vision can be associated with both insufficient illumination and excessive illumination, as well as with the wrong direction of light.

According to the standards, the illumination on the surface of the table in the area where the working document is placed should be 300-500 lux. Lighting should not create glare on the screen surface. The illumination of the screen surface should not exceed 300 lux [25].

The brightness of general lighting fixtures in the zone of radiation angles from 50 to 90 ° with the vertical in the longitudinal and transverse planes should be no more than 200 cd / m, the protective angle of the fixtures should be at least 40 °. The safety factor (Kz) for lighting installations for general lighting should be taken equal to 1.4. The ripple factor should not exceed 5%.

Artificial lighting in the premises for the operation of a PC should be carried

out:

– general uniform lighting system.

In production and administrative-public premises, in cases of predominant work with documents, the following systems should be used:

- combined lighting (lamps are additionally installed in addition to general lighting;

– local lighting designed to illuminate the area where documents are located)

[25].

Room area:

$$S = a \cdot b, \quad (89)$$

where a – length, m; b – width, m.

$$S = 6 \cdot 6 = 36 \text{ м}^2.$$

Reflectivity of freshly whitewashed walls with windows covered with white curtains $\rho_C = 70 \%$, freshly whitewashed ceiling $\rho_{II} = 70 \%$. The safety factor, taking into account the contamination of the luminaire, for rooms with low dust emission is equal to $K_s = 1,5$. Coefficient of unevenness for LED strips $Z = 1,1$.

We choose Varton 9w LEDs, the luminous flux of which is equal to $\Phi_{\text{лп}} = 2900 \text{ лм}$.

We choose fixtures with LEDs such as Diora LPO. This luminaire has two LED strips with a power of 9 W each, the length of the luminaire is 1260 mm, the width is 124 mm.

The integral criterion for the optimal location of luminaires is the value λ , which for LED lamps with a protective diffuser lies in the range of 1.1 - 1.3. Accept $\lambda = 1,1$, distance of luminaires from ceiling (overhang) $h_c = 0,5 \text{ м}$.

The height of the luminaire above the working surface is determined by the formula:

$$h = h_n - h_p, \quad (90)$$

where h_n – lamp height above the floor, suspension height;

h_p – the height of the work surface above the floor.

The smallest permissible suspension height above the floor for Diora double-strip luminaires: $h_n = 3,5$ м.

The height of the luminaire above the working surface is determined by the formula:

$$h = H - h_p - h_c = 3,5 - 1 - 0,5 = 2 \text{ м.} \quad (91)$$

From the formula

$$\Phi_n = \frac{(E \cdot S \cdot K_3 \cdot Z)}{N \cdot \eta}, \quad (92)$$

find the number of LED strips N :

$$N = \frac{(E \cdot S \cdot K_3 \cdot Z)}{\Phi_n \cdot \eta}. \quad (93)$$

η determined through the room index by the formula:

$$i = \frac{(a \cdot b)}{h \cdot (a + b)} = \frac{6 \cdot 6}{2(6 + 6)} = 1,5. \quad (94)$$

The luminous flux utilization factor, showing what part of the luminous flux of the lamps falls on the work surface, for Diora luminaires with LED strips at $\rho_{II} = 70 \%$, $\rho_C = 70 \%$ and room index $i = 1,5$ equals $\eta = 0,54$.

Then

$$N = \frac{(E \cdot S \cdot K_3 \cdot Z)}{\Phi_n \cdot \eta} = \frac{300 \cdot 36 \cdot 1,5 \cdot 1,1}{2900 \cdot 0,54} = 11,38 \text{ лент.}$$

We accept the number of LED strips 12. This results in 6 lamps, that is, 2 rows of 3 lamps.

Required luminous flux of LED lamps:

$$\Phi_n = \frac{(E \cdot S \cdot K_3 \cdot Z)}{N \cdot \eta} = \frac{300 \cdot 36 \cdot 1,5 \cdot 1,1}{12 \cdot 0,54} = 2750 \text{ лм.}$$

From the conditions of uniformity of illumination, we determine the distances L_1 и $\frac{L_1}{3}$, L_2 и $\frac{L_2}{3}$ according to the following equations:

$$6000 = L_1 + \frac{2}{3} \cdot L_1 + 2 \cdot 124; L_1 = 3451 \text{ мм, } \frac{L_1}{3} = 1150 \text{ мм;} \quad (95)$$

$$6000 = 2 \cdot L_2 + \frac{2}{3} \cdot L_2 + 3 \cdot 1260; L_2 = 832 \text{ мм}, \frac{L_2}{3} = 277 \text{ мм}; \quad (96)$$

Figure 33 shows the plan of the premises and placement of lamps with LED strips in the laboratory № 102–11 of the TPU educational building.

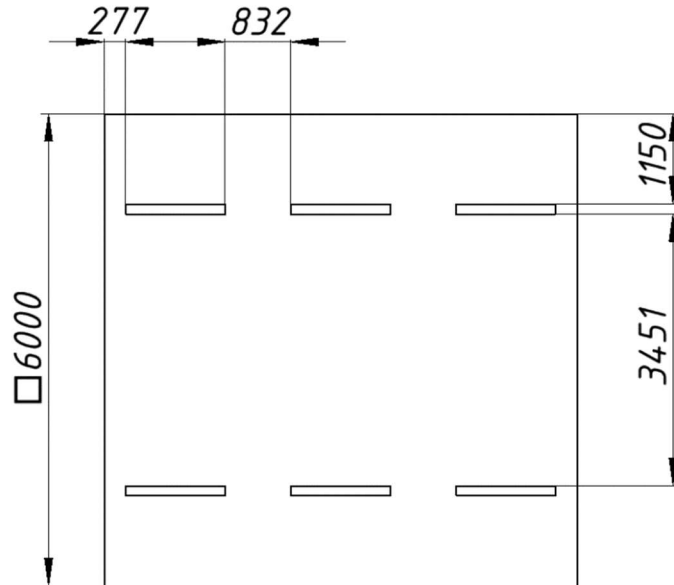

Figure 33 - Plan of the room and placement of luminaires with LED strips

Making a condition check:

$$-10\% \leq \frac{(\Phi_{л\delta} - \Phi_{л})}{\Phi_{л\delta}} \cdot 100\% \leq 20\%; \quad (97)$$

$$\frac{(\Phi_{л\delta} - \Phi_{л})}{\Phi_{л\delta}} \cdot 100\% = \frac{(2900 - 2750)}{2900} \cdot 100\% = 5,2 \%$$

Thus, it is obtained that the required luminous flux does not go beyond the required range. The power of the lighting installation turned out:

$$P = 12 \cdot 9 = 108 \text{ Вт.}$$

The calculated number of lamps and the distance between them in the classroom № 102 11 of the TPU educational building corresponds to the actual.

4.3.4. Exceeding the noise level

Noise, being a general biological stimulus, affects not only the auditory analyzer, but also affects the structures of the brain, causing shifts in various

functional systems of the body. Among the numerous manifestations of the adverse effects of noise on the human body, the following stand out: a decrease in speech intelligibility, discomfort, the development of fatigue and a decrease in labor productivity, the appearance of noise pathology. Table 30 shows the noise level standards for various types of work.

Table 29 - Noise level standards for various types of work

| | Maximum permissible noise level (dB), in the bands of the following octaves (Hz) | | | | | | | | | Equivalent noise levels, dBA |
|---------------------------------------|--|----|----|----|----|----|----|----|----|------------------------------|
| Scientific work, calculations, design | 86 | 71 | 61 | 54 | 49 | 45 | 42 | 40 | 38 | 50 |
| Offices, laboratories | 93 | 79 | 70 | 68 | 58 | 55 | 52 | 52 | 49 | 55 |

The noise level at workplaces while working on a PC should not exceed 55 dB. To reduce the noise level, the ceiling or walls should be lined with sound-absorbing material with a maximum sound absorption coefficient in the frequency range from 63 to 8000 Hz [31]. Curtains on the windows made of dense heavy fabric serve as additional sound absorption.

In laboratory № 102 11 of the educational building of TPU, the noise level complies with sanitary standards [31].

4.3.5. Psychophysiological factors

Psychophysiological dangerous and harmful production factors are divided into: physical overload (static, dynamic) and neuropsychic overload (mental overstrain, monotony of work, emotional overload).

The labor activity of workers in the non-productive sphere belongs to the category of work associated with the use of large amounts of information, with the use of computerized workplaces, with frequent making of responsible decisions in conditions of time pressure, direct contact with people of different types of

temperament, etc. This causes a high level of neuropsychic overload, reduces the functional activity of the central nervous system, leads to disorders in its activity, the development of fatigue, overwork, stress.

The most effective means of preventing fatigue during work in production are means that normalize the active labor activity of a person. Against the background of the normal course of production processes, one of the important physiological measures against fatigue is the correct mode of work and rest [25].

To reduce the impact of harmful factors, a framework for the duration of breaks is established. Table 31 shows the total rest time for each category of work [32].

Table 30 - Total break time depending on the category of work and load

| Job category | The level of load per work shift for types of work with a PC | | | Total time of regulated breaks |
|--------------|--|-------------------------------|----------------|--------------------------------|
| | Group A, number of characters | Group B, number of characters | Group B, hours | at 8-hour shift, min. |
| I | up to 20 000 | up to 15 000 | up to 2 | 50 |
| II | up to 40 000 | up to 30 000 | up to 4 | 70 |
| III | up to 60 000 | up to 40 000 | up to 6 | 90 |

In this case, the load level refers to group B, work category III. According to the table, it is required to set breaks, the sum of which for working time will be at least 90 minutes, that is, breaks of 15 minutes each working hour [32].

4.3.6. Electrical safety

According to [26], depending on the conditions in the room, the risk of electric shock to a person increases or decreases. You should not work with a computer in conditions of high humidity (relative air humidity exceeds 75% for a long time), high temperature (more than 35 ° C), the presence of conductive dust,

conductive floors and the possibility of simultaneous contact with ground-connected metal elements and the metal case of electrical equipment. The office belongs to the 1st category in terms of electrical safety, since there are no electrical installations with voltages over 1000 V at the workplace.

The computer operator works with electrical appliances: a computer (display, system unit, etc.) and peripheral devices. There is a risk of electric shock in the following cases:

- by direct contact with current-carrying parts during computer repair;
- when touching non-current-carrying parts that are energized (in case of violation of the insulation of the current-carrying parts of the computer);
- when touching the floor, walls that are energized;
- in case of short circuit in high-voltage units: power supply unit and display scanner unit.

Measures to ensure the electrical safety of electrical installations:

- - disconnection of voltage from current-carrying parts on which or near which work will be carried out, and taking measures to ensure that it is impossible to supply voltage to the place of work;
- - hanging posters indicating the place of work;
- - grounding of housings of all installations through a neutral wire;
- - coating of metal surfaces of tools with reliable insulation;
- - inaccessibility of current-carrying parts of the equipment (conclusion in cases of electro-damaging elements, current-carrying parts) [26].

When performing this WRC, a PC was used. This device is powered by a mains voltage of 220 V at a frequency of 50 Hz with a rated power consumption of 0.18 kW. When using this equipment, the requirements for electrical safety [26].

4.4 Environmental safety

The work is developing a model of the ROKUS-AMT gamma-ray installation, using a PC.

The impact of equipment operation on the environment is minimal. The greatest harm from them in work is the consumption of electricity. The PC does not emit harmful substances, does not create radiation that can violate the environmental safety of nature. However, its production and disposal are a serious problem. Thus, in the production of PCs, heavy, alkaline earth metals, mercury, plastic and glass are used, which, without proper disposal at the end of their service life, enters nature and remains unprocessed from a century to one and a half thousand years [25].

Activities that allow you to maintain environmental safety while at the workplace [25]:

- correct disposal;
- use of energy-saving lamps;
- use of accumulators instead of saline batteries.

Reducing the level of environmental pollution is possible due to more efficient and economical use of electricity by consumers themselves. This is the use of more economical equipment, as well as an efficient mode of loading this equipment. This also includes the observance of production discipline in the framework of the correct use of electricity [25].

From this we can draw a simple conclusion that it is necessary to strive to reduce energy consumption, to responsibly treat the disposal of various devices, since they can decompose in the environment up to hundreds of years.

4.5 Fire and explosion safety

According to [33], depending on the characteristics of the substances used in the production and their quantity, according to fire and explosion hazard, the premises are divided into categories A, B, C, D, E. Since the laboratory room belongs to category C according to the degree of fire and explosion hazard, i.e. e. to rooms with solid combustible substances, it is necessary to provide a number of preventive measures.

Possible causes of fire [28]:

- work with open electrical equipment;

- short circuits in the power supply;
- non-compliance with fire safety rules;
- the presence of combustible components: documents, doors, tables, cable insulation, etc.

Fire prevention measures are divided into: organizational, technical, operational and regime [28].

Organizational measures provide for the correct operation of equipment, the correct maintenance of buildings and territories, fire safety briefing for workers and employees, training of production personnel in fire safety rules, publication of instructions, posters, and the availability of an evacuation plan [28].

Technical measures include: compliance with fire regulations, standards in the design of buildings, in the installation of electrical wires and equipment, heating, ventilation, lighting, proper placement of equipment [25].

Regime measures include the establishment of rules for the organization of work, and compliance with fire prevention measures. To prevent a fire from short circuits, overloads, etc., the following fire safety rules must be observed [25]:

- exclusion of the formation of a combustible environment (sealing of equipment, air control, working and emergency ventilation);
- correct operation of the equipment (correct connection of the equipment to the power supply network, control of equipment heating);
- correct maintenance of buildings and territories (exclusion of the formation of an ignition source - prevention of spontaneous combustion of substances, restriction of hot work);
- training of production personnel in fire safety rules;
- publication of instructions, posters, availability of an evacuation plan;
- compliance with fire regulations, norms in the design of buildings, in the installation of electrical wires and equipment, heating, ventilation, lighting;
- proper placement of equipment;

- timely preventive inspection, repair and testing of equipment.

In the event of a fire, inform the manager, the fire safety authorities of the enterprise and proceed to extinguish the fire with a fire extinguisher.

In the event of an emergency, it is necessary [28]:

- inform management (duty officer);
- call the relevant emergency service or the Ministry of Emergency Situations by phone - 112;
- take measures to eliminate the consequences of the accident in accordance with the instructions [33].

4.6 Emergency Safety

4.6.1. Analysis of typical emergencies during the study

An emergency situation (ES) is a situation that has developed in a certain territory as a result of an accident, a natural hazard, a catastrophe, a natural or other disaster that may result in loss of life, damage to human health or the environment, significant material losses and violation of living conditions. of people.

During the study, the most probable emergency is a fire. A fire in a work area can be caused by non-electrical and electrical causes. Table 32 discusses possible emergency situations, methods for their prevention and elimination of their consequences.

Table 31 - Emergencies, methods for their prevention and elimination of consequences

| № | Emergency | Emergency prevention methods | Elimination of consequences of emergencies |
|---|----------------|---|--|
| 1 | Fire | 1) check the condition of electrical devices and heating appliances; 2) comply with fire safety rules in accordance with the requirements of regulatory documentation; 3) conduct training and briefing of employees, develop fire fighting skills; | 1) in the event of a fire, call 01,101,112; 2) use powder and carbon dioxide fire extinguishers as extinguishing agents |
| 2 | Electric shock | 1) prevent damage to the insulation of current-carrying parts of electrical installations; | 1) turn off the voltage on the damaged installation; 2) fence off the place, put up signs; |

| | | | |
|---|----------------------------------|--|---|
| | | <p>2) conduct scheduled inspections of electrical equipment;</p> <p>3) observe the permissible distance between insulators and wires;</p> <p>4) comply with safety regulations and technical operation;</p> <p>5) conduct training and briefing of employees;</p> <p>6) install protective grounding.</p> | <p>3) if there are victims, provide first aid and call an ambulance by calling 112, 103</p> |
| 3 | Injury from a fall from a height | <p>1) it is necessary to make sure that computer wires are not in the way of movement, in case of violation, inform the manager;</p> <p>2) do not use a chair, table, etc. instead of a ladder;</p> <p>3) prevent the placement of equipment and documentation on shelves and cabinets, access to which is impossible without a ladder;</p> <p>4) when moving up the stairs, it is always necessary to hold on to the handrail and look under your feet;</p> <p>5) do not keep your hands in your pockets, because in case of a fall, instinctive movements will help you stay on your feet;</p> <p>6) never carry objects, holding them in front of you, blocking the view;</p> <p>7) clean shoes from dirt, ice and other contaminants before entering the building;</p> <p>8) to train and instruct employees</p> | <p>1) examine the body and head of the victim for open wounds and abrasions;</p> <p>2) ask to make movements with your fingertips, which will eliminate damage to the spine;</p> <p>3) movement of arms and legs will eliminate the presence of fractures;</p> <p>4) to interrogate the victim about violations of general well-being: dizziness, drowsiness, nausea - these signs indicate a concussion;</p> <p>5) in the absence of serious injuries, a cold compress is placed on the site of the bruise and the victim is escorted home;</p> <p>6) in case of serious injuries, you must call 03 (103) or 112 and report the incident</p> |

Section Conclusions

This section analyzes the harmful and dangerous factors that may arise in the workplace during research:

- microclimate [25];
- noise and vibration [31];
- electromagnetic radiation [27];
- illumination [25];
- psychophysiological factors [25];
- electrical safety [26];

– fire and explosion safety [28].

Room № 102 11 of the TPU building is assigned to:

– in electrical safety – to class 1 [26];

- in terms of fire and explosion safety - to category B [28].

Possible emergency situations, methods of their prevention and elimination of consequences are also considered.

MAIN RESULTS AND CONCLUSIONS

A mathematical description of the processes occurring in a separating cell under the action of an electric field has been developed. The model represents a 2nd order partial differential equation with boundary conditions.

An analytical and numerical solution of the differential equation is performed. The smallest discrepancy between the numerical and analytical solution is 9%, the standard deviation of the numerical solution is 0.006.

The parameters that affect the separation process are determined - these are the solution flow rate and the electromigration rate. The main contribution to the change in concentration is made by the rate of electromigration.

This model can be used in the future for planning experiments with the imposition of alternating electric fields.

LIST OF USED SOURCES

1. Hubbell JH. Photon cross sections, attenuation coefficients, and energy absorption coefficients from 10 keV to 100 GeV. National Bureau of Standards report NSRDS-NSB 29; August 1969
2. Мухин К.Н. Экспериментальная ядерная физика. В двух томах. Т. 1. Физика атомного ядра. Учебник для вузов. Изд. 3-е М., Атомиздат, 1974 г., 584 с.
3. РД-07-15-2002. Федеральный надзор России по ядерной и радиационной безопасности [Текст]. – Введ. 2003-05-10. – М.: Гостатомнадзор России.
4. Кондратьев В.Н. Кинетика химических газовых реакций, М.: АН СССР, 1958. — 693 с.
5. Kirk-Othmer encyclopedia of chemical technology. Vol.21. - 5th ed. - Hoboken: Wiley-Interscience, 2006. Radioisotopes and Radiation Methodology I, II. Soo Hyun Byun, Lecture Notes. McMaster University, Canada.
6. Источники Гамма - излучения: [Электронный ресурс] // Изотоп Ростатом. URL: <http://www.isotop.ru/files/treecontent/nodes/attaches/0/95/noname..pdf>. (Дата обращения 15.04.2022).
7. Сталь марки 12X18Н10Т: [Электронный ресурс] // Центральный металлический портал. URL: https://metallcheckiy-portal.ru/marki_metallov/stk/12X18H10T (Дата обращения 15.04.2022).
8. Сталь марки AISI316: [Электронный ресурс] // Центральный металлический портал. URL: https://metallcheckiy-portal.ru/marki_metallov/stn/AISI316 (Дата обращения 15.04.2022).
9. Geant4 A simulation toolkit: [Электронный ресурс]. URL: <https://geant4.web.cern.ch/>. (Дата обращения 15.02.2022).
10. G4NistMaterialBuilder.cc: [Электронный ресурс]. URL: https://apc.u-paris.fr/~franco/g4doxy/html/G4NistMaterialBuilder_8cc-source.html. (Дата обращения 20.04.2022).

11. Physics Reference Manual: [Электронный ресурс]. URL: <https://indico.cern.ch/event/679723/contributions/2792554/attachments/1559217/2454299/PhysicsReferenceManual.pdf>. (Дата обращения 20.04.2022).
12. F.Biggs et al. Hartree-fock compton profiles for the elements. At. Data Nucl. Data Tables, 16():201, 1975.
13. U. Fano. Penetration of protons, alpha particles and mesons. Ann. Rev. Nucl. Sci., 13():1, 1963.
14. D. Cullen, J.H. Hubbell, and L. Kissel. Epd197: the evaluated photon data library, '97 version. UCRL-50400, 6(Rev.5);, 1989. <http://reddog1.llnl.gov/homepage.red/photon.htm>.
15. M.J. Berger and J.H. Hubbel. Xcom: photom cross sections on a personal computer. Technical Report Report NBSIR 87-3597, National Bureau of Standards, 1987.
16. S.M.Seltzer S.T.Perkins, D.E.Cullen. Tables and graphs of electron-interaction cross-sections from 10 ev to 100 gev derived from the llnl evaluated electron data library (eedl), z=1-100. Technical Report UCRL-50400 Vol.31, Lawrence Livermore National Laboratory, 1989.
17. D.H. Wilkinson. Evaluation of the fermi function; EO competition. Nuclear Instruments and Methods, 82:122–124, may 1970. URL: [https://doi.org/10.1016/0029-554X\(70\)90336-8](https://doi.org/10.1016/0029-554X(70)90336-8), doi:10.1016/0029-554x(70)90336-8.
18. ROOT: analyzing petabytes of data, scientifically: [Электронный ресурс]. URL: <https://root.cern/>. (Дата обращения 15.02.2022).
19. RAPIDXML: [Электронный ресурс]. URL: <http://rapidxml.sourceforge.net/>. (Дата обращения 20.04.2022).
20. CMake: [Электронный ресурс]. URL: <https://cmake.org/>. (Дата обращения 20.04.2022).
21. Видяев И.Г. Финансовый менеджмент, ресурсоэффективность и ресурсосбережение: учебно– методическое пособие / И.Г. Видяев, Н.А. Гаврикова, Г.Н. Серикова. – Томск: НИ ТПУ, 2014. – 36 с.

22. Трудовой кодекс Российской Федерации от 30.12.2001 № 197-ФЗ (ред. от 08.05.2022) // Собрание законодательства РФ. - 07.01.2002.
23. Федеральный закон «Об основах охраны труда» от 17.07.1999 г. № 181-ФЗ
24. СанПиН 2.2.2/2.4.1340-03 «Гигиенические требования к персональным электронно-вычислительным машинам и организации работ».
25. СанПиН 1.2.3685-21 «Гигиенические нормативы и требования к обеспечению безопасности и (или) безвредности для человека факторов среды обитания».
26. ГОСТ 12.1.038-82 «ССБТ. Электробезопасность».
27. СанПиН 2.2.4/2.1.8.055-96 «Электромагнитные излучения радиочастотного диапазона».
28. ГОСТ 12.1.004-91 «ССБТ. Пожарная безопасность».
29. СНиП 41-01-2003. ОТОПЛЕНИЕ, ВЕНТИЛЯЦИЯ И КОНДИЦИОНИРОВАНИЕ: дата введения 2004-01-01. – URL: <https://docs.cntd.ru/document/1200035579> (дата обращения: 10.05.2022). – Текст : электронный.
30. Vents : сайт. – 2017-2021.– URL: <https://vents-shop.ru/ventilyator-vents-150-vko/> (дата обращения 07.05.2022). – Текст: электронный.
31. СП 51.13330.2011 Защита от шума. Актуализированная редакция СНиП 23-03-2003 (с изменением № 1)
32. ТОИ Р-45-084-01. Типовая инструкция по охране труда при работе на персональном компьютере: дата введения 2001-07-01. – URL: <https://docs.cntd.ru/document/1200030047/> (дата обращения 10.05.2022). – Текст: электронный.
33. Российская Федерация. Законы. Технический регламент о требованиях пожарной безопасности (с изменениями на 27 декабря 2018 года) : Федеральный Закон № 123-ФЗ : [Принят Государственной Думой 4 июля 2008 года]. – Москва, 2018. – 103 с.

SUPPLEMENT A

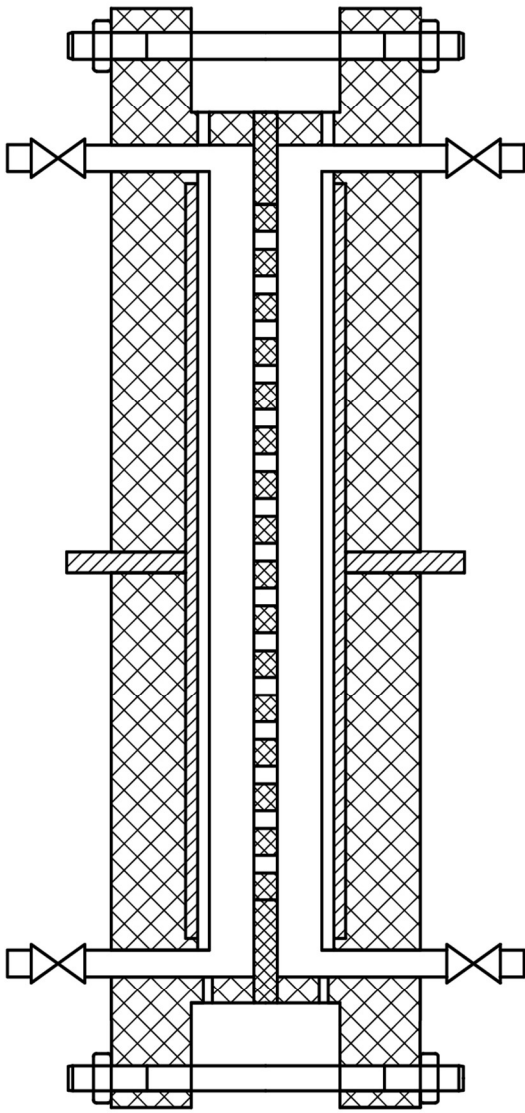
| | | | | | | | | | | | |
|---------------|---|------|----------|-------|------|--------------------------------|------------------------------|-------|---------|--------|---|
| Перв. примен. | ФЮРА.066136.011 В0 | | | | | | | | | | |
| Справ. № |  | | | | | | | | | | |
| Подп. и дата | | | | | | | | | | | |
| Инв. № дубл. | | | | | | | | | | | |
| Взам. инв. № | | | | | | | | | | | |
| Подп. и дата | ФЮРА.066136.011 В0 | | | | | | | | | | |
| Инв. № подл. | Изм. | Лист | № докум. | Подп. | Дата | Экспериментальная Установка | Лит. | Масса | Масштаб | | |
| | | | | | | | У | | | 1:2 | |
| | | | | | | | | Лист | 2 | Листов | 2 |
| | | | | | | | ТПУ ИЯТШ ОЯТЦ Группа ОАВД | | | | |
| | | | | | | | | | | | |
| | | | | | | Копировал _____ Формат А4 | | | | | |